

# K7VG series Axial Piston Pumps Service Manual

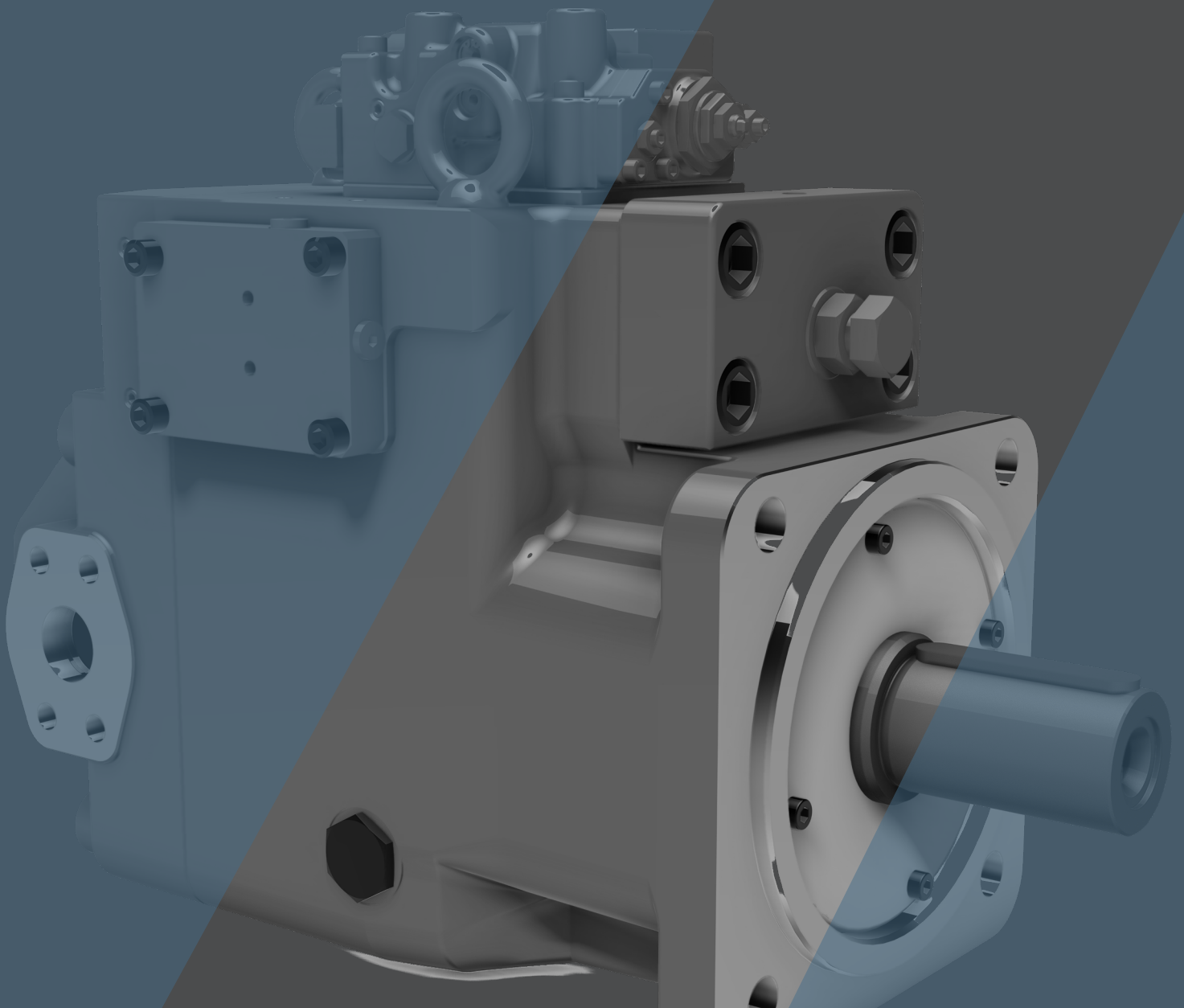

# CONTENTS

<b>Specifications and Features</b>	2
<b>1. Ordering Code</b>	3
<b>2. Technical Information</b>	
2-1. Technical Data	4 - 6
2-2. Specifications	7 - 8
2-3. Performance Data	9 - 10
2-4. Bearing Life Data	11
2-5. Functional Description of Regulators	12 - 14
2-6. Horsepower Limiter Settings	15
2-7. Installation	16 - 18

# K7VG Series

## Swash-plate Axial Piston Pump

### ■ General Descriptions

#### Reliable High-Pressure and Long-Life Type

This series of high-pressure, swash-plate type pumps was developed for general industrial machinery use and is based upon our long and rich experience. The adoption of the high-load bearings and friction-free contacting mechanism of shoes has achieved high reliability and long life.

#### Low Noise

The unique compact and rigid housing construction in addition to the semi-cylindrical swash-plate and its anti-vibration supporting mechanism has both reduced noise and pressure pulsations

#### High Efficiency and High Self-Priming Capability

The spherical valve plate and improved hydraulic balance provide stable cylinder rotation, thus achieving high efficiency even in a low-pressure and low-speed operating range. Additionally the shortened radius of the cylinder port reduces the peripheral fluid velocity thereby enabling its high self-priming speed capability.

#### Varieties of Control Methods

Good varieties of hydraulic and electrical control methods are available. The flow control, pressure control, horsepower control, and the combination of these are standardized and available.

#### Auxiliary Gear Pump

Various sizes of auxiliary pumps can be attached the rear SAE throughdrive mounting interface. Accordingly, there is no need for a separate pump unit as a control pressure source or as a medium-pressure system pressure source. Hydraulic units can thus be made compact.

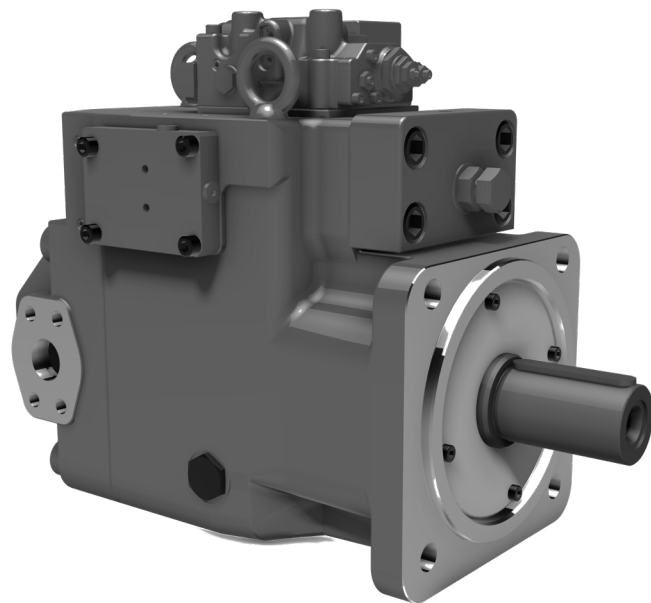

### ■ Features

**343 bar rating**

**Long Bearing Life**

**ISO Mount and Shaft**

**Optional Throughdrive**

**High Reliability**

**High Efficiency**

**Low Noise**

**Highly Responsive Controls**

Pump Model		K7VG180	K7VG265	
Displacement (cm <sup>3</sup> )		180	270	
Pressure (bar)	Rated	343		
	Peak	400		
Maximum Self Priming Speed (rpm)		1,850	1,500	1,600*
Maximum Boosted Speed (rpm)		2,200	1,500	1,900*

\*for high speed version

# 1 Ordering Code

## K7VG265/-/1/N/N/R/H/C/N/H1/3/N/4D/-0

### K3VL Series Pump

#### Maximum Displacement

180	180 cm <sup>3</sup> /rev
265	270 cm <sup>3</sup> /rev

#### Hydraulic Fluid Type

-	Mineral Oil
P	Viton Seals Throughout
W	Water Glycol

#### Circuit Type

1	Open Circuit
---	--------------

#### Through Drive & Porting

N	Steel Cover, No Through Drive
A	SAE-A Through Drive
B	SAE-B Through Drive
C	SAE-C Through Drive
CC	SAE-CC Through Drive
D	SAE-D Through Drive

#### Mounting Bracket / Port Flange

N	No Bracket, No Port Flange
---	----------------------------

#### Direction of Rotation

R	Clockwise Rotation
---	--------------------

#### Series Type

-	Standard Series
H	High Speed Series

#### Regulator Type

0 <sup>(2)</sup>	No regulator fitted
1 <sup>(2)</sup>	Top mounted torque limiter only
4 <sup>(2)</sup>	Side mounted direct acting pressure compensator only
5 <sup>(2)</sup>	Top mounted torque limiter & side mounted direct acting pressure compensator
7 <sup>(2)</sup>	Top mounted torque limiter with load sensing & remote pressure compensator
C	Side mounted remote pressure compensator only
D	Top mounted torque limiter with side mounted remote pressure compensator
E	Side mounted load sensing compensator
F	Top mounted torque limiter & side mounted load sensing compensator

### Tilt monitor & other accessories

Blank	With tilt monitor only
0 <sup>(2)</sup>	Without tilt monitor only
2 <sup>(2)</sup>	With 1,000-1,200 rpm resonator
3 <sup>(2)</sup>	With 1,500-1,800 rpm resonator
4 <sup>(2)</sup>	1,000-1,200 rpm resonator & tilt monitor
6 <sup>(2)</sup>	1,500-1,800 rpm resonator & tilt monitor

### Unload or remote control solenoid & electrical connections <sup>(1)</sup>

00	Without unload or remote control valve
1A	Unload valve with 115V AC 50/60Hz DIN 43550 plug
2A	Unload valve with 230V AC 50/60Hz DIN 43550 plug
2D	Unload valve with 12V DC DIN 43550 plug
4D	Unload valve with 12V DC DIN 43550 plug
A0	Remote control valve (SUN source) with Deutz connector
B0	Remote control valve (SUN source) with DIN connector

### Additional Pressure Control Options

1	R4 plugged (regulator types e & f only)
N	With integrated unloading valve (normally closed)
M	With integrated unloading valve (normally open)
V	With integrated remote control valve (Kpm source, DIN connector)
W	With integrated remote control valve (Sun source)
0	None

### Pressure Control - Additional Code <sup>(1)</sup>

3	Always for types C, D, E & F
0	All other regulator types

### Top mounted Torque Limiter

00	None (types 0, 4, C, E only)
H#	High setting range
M#	Medium setting range

### Top Mounted Flow Control Type

0	No flow control
1	No flow control (type 4 only)
N	Negative flow control
P	Positive flow control
E	Electrical displacement control (required Pilot pressure source)
L	Load sensing (type 7 only)

<sup>(1)</sup> Only available for code C,D,E& F, otherwise blank

<sup>(2)</sup> Non Standard Options - Contact KPM UK

# 2 Technical Information

## 2-1 Technical Data

For applications outside the following parameters, please consult KPM UK.

### ◆ Hydraulic Data

**Pressure Fluid** Mineral oil, polyol ester and water glycol.

Use a high quality, anti-wear, mineral based hydraulic fluid when the pressure exceeds 206 bar. In applications where fire resistant fluids are required consult KPM UK.

### ◆ Fluid selection

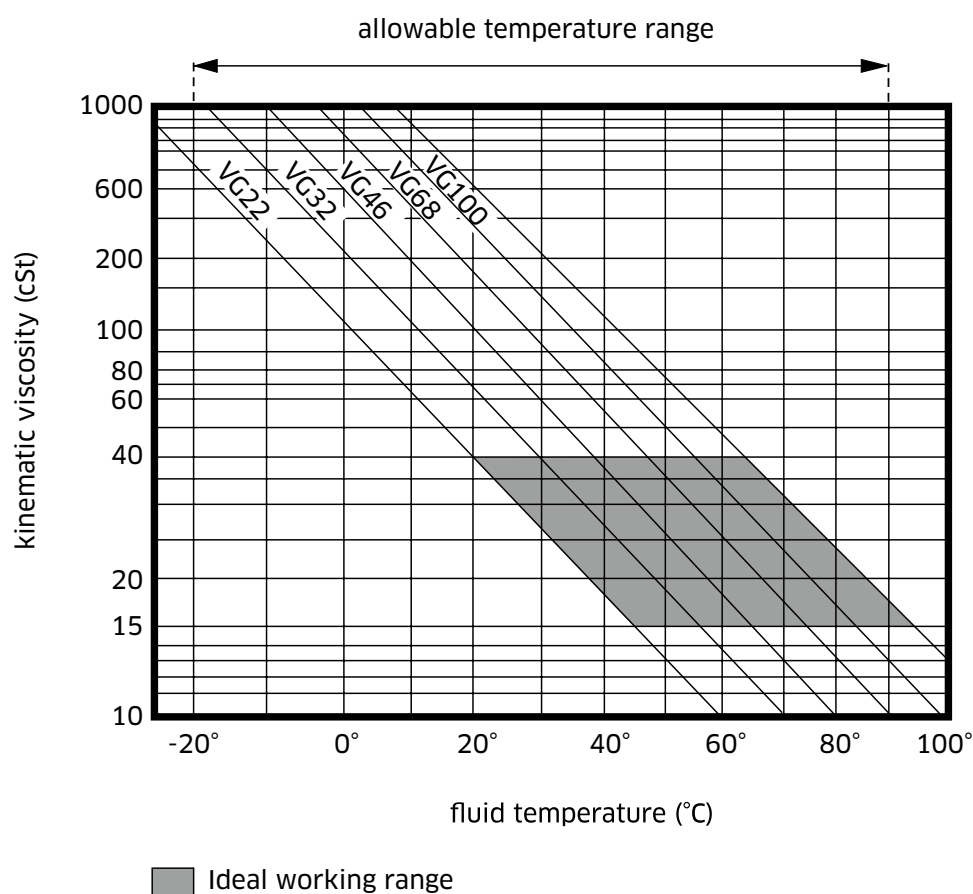

## 2-1 Technical Data (cont)

### ◆ Filtration & Contamination Control

#### Filtration

The most important means to prevent premature damage to the pump and associated equipment and to extend its working life, is to ensure that hydraulic fluid contamination control of the system is working effectively.

This begins by ensuring that at the time of installation that all piping, tanks etc. are rigorously cleaned in a sanitary way. Flushing should be provided using an off line filtration system and after flushing the filter elements should be replaced.

A full flow return line filter of 10 micron nominal should be utilised to prevent contaminant ingress from the external environment, a 5 to 10 micron filter within the tank's breather is also recommended.

### ◆ Suggested Acceptable Contamination Level

The relationship between contamination level and pump life is very difficult to predict as it depends on the type and nature of the contaminant present in the system. Sand or Silica in particular, due to its abrasive nature, does significantly reduce the expected life of a pump. Based on the precondition that there is no significant presence of Silica type substances then a minimum Cleanliness level of -/18/15 ISO 4406 or SAE AS 4059E Table 1 Class 9 (NAS 1638 Class 9).

### ◆ Working Fluid Types

#### Anti-Wear Type Hydraulic fluid

It is generally recommended to use an anti-wear hydraulic fluid like mineral oil when the operating pressure exceeds 206 bar.

#### Fire-resistant Fluids

Some kind of fire-resistant fluids require special materials for seals, paint and metal finishing. Please consult KPM UK and provide details of the particular fluid specification and the working conditions so that any special requirements can be ascertained.

In general, fire-resistant fluids have a low viscosity index and their viscosity also changes significantly with operating temperature and service life. For this reason, the circuit should be provided with an adequately sized cooler or forced cooling so that temperatures can be stabilised. Due to the inherent water content of some of these fluids the minimum allowable suction pressure will be higher than that of an equivalent mineral oil and so needs to be fully evaluated by KPM UK. The following table provides an overview of the precautions and characteristics that can be expected with these types of fluids.

Fluid Type Parameter	Mineral Oil	Polyol Ester	Water Glycol
Maximum Pressure (bar)	343	245	206
Recommended Temperature Range (deg C)	20 ~ 60	20 ~ 60	10 ~ 50
Cavitation susceptibility	○	△	△
Expected life expectancy compared to mineral oil	100%	50%	20%

○ recommended      △ usable (higher density)

## 2-1 Technical Data (cont)

### ◆ Pump Start Up Precautions

#### Pump Case Filling

Be sure to fill the pump casing with oil through the drain port, filling only the suction line with oil is totally insufficient. The pump contains bearings and high-speed sliding parts including pistons with shoes and spherical bushes that need to be continuously lubricated. Part seizure or total premature failure will occur very quickly if this procedure is not rigidly followed.

#### Piping & Circuit Checking

Check to see that the piping and full hydraulic circuit is completed and that any gate valves etc. are open.

#### Direction of Rotation

Check to ensure that direction of rotation is correct and that the inlet and delivery lines are connected correctly.

#### Start Up

Jog start the motor and check once more for correct rotation. Run the pump unloaded for a period to ensure that all residual air within the system is released. Check for external leakage, abnormal noise and vibrations.

#### Case Drain Pressure

Please ensure, that the maximum steady state drain line pressure at the pump casing does not exceed 1 bar. (Maximum peak pressure 4 bar). A suitable drain line hose must be selected and return directly back to the tank and terminate below the oil level.

#### Long Term Out of Usage

It is undesirable to leave the pump out of use for a long period e.g. a year or more. In such a situation it is recommended that the pump is run for a short period on a more frequent basis even if it is just unloaded. With regard to a pump held in storage then rotating the shaft on a frequent basis is sufficient. If the pump is left out for more than the suggested time it will require a service inspection.

## 2-2 Specifications

For applications outside of the following parameters please contact KPM UK.

Pump Model		K7VG180	K7VG265	
Displacement (cm <sup>3</sup> )		180	270	
Pressure (bar)	Rated	343		
	Peak	400		
Maximum Self Priming Speed	(rpm)	1,850	1,500	1,600*
Maximum Boosted Speed	(rpm)	2,200	1,500	1,900*
Mass	(kg)	145	225	

\*for high speed version

### ◆ Moments of Inertia

Frame Size	180	265
MMOI GD2 (kgf.m <sup>2</sup> )	1.70x10 <sup>-2</sup> (4.25-10 <sup>-3</sup> )	4.98x10 <sup>-2</sup> (1.25x10 <sup>-2</sup> )
Torsional stiffness (Nm/rad)	2.07x10 <sup>5</sup>	5.47x10 <sup>4</sup>



## 2-2 Specifications (cont)

**#1** Maximum allowable shaft torques are based on achieving an infinite life for a coupling assembly that is lubricated and completely clamped and utilises the full spline/key length as engagement.

The following points therefore need to be fully considered:-

- i) Lubrication of shaft couplings should be in accordance with the coupling manufacturers instructions.
- ii) The maximum allowable input shaft torque is based on ensuring an infinite life condition by limiting the resultant combined shaft bending and torsional stress.
- iii) This allowable input shaft torque can be further increased dependant on the resultant surface stress at the spline interface which is highly dependant on coupling selection and the provision of adequate spline lubrication.

If you have an application that requires higher input torque please consult KPM UK.

**#2** Allowable through drive torques are based on the achieving an infinite life for a fully lubricated coupling and full spline engagement with a mineral oil based anti-wear hydraulic fluid.

Notes:

### Rated Pressure

Pressure at which life and durability will not be affected.

### Peak Pressure

The instant allowable surge pressure as defined by BS ISO 2944:2000. Life and durability however will be shortened.

### Maximum Self Priming Speed

Values are valid for an absolute suction pressure of 1 bar. If the flow is reduced and the inlet pressure is increased the speed may also be increased.

### Maximum Boosted Speed

Values stated are the absolute maximum permitted speed for which an increased inlet pressure will be required.

### Weight

Approximate dry weights, dependant on exact pump type.

### Hydraulic Fluid

Mineral anti wear hydraulic fluid - for other fluid types please consult KPM UK.

### Viscosity Range

If viscosity is in range 200 to 1,000 cSt, then warming up is necessary before commencing full scale running.

## 2-3 Performance Data

### K7VG180

#### ◆ Pump Efficiency (%)

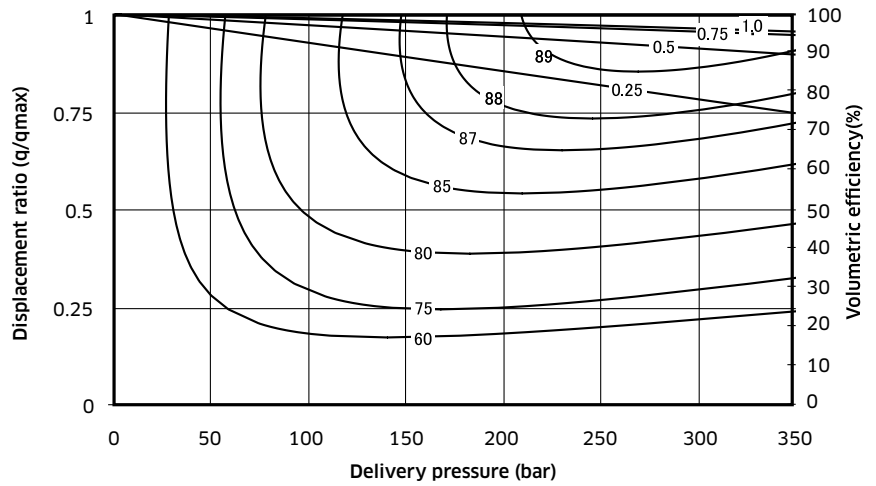

#### ◆ Self Priming Capability

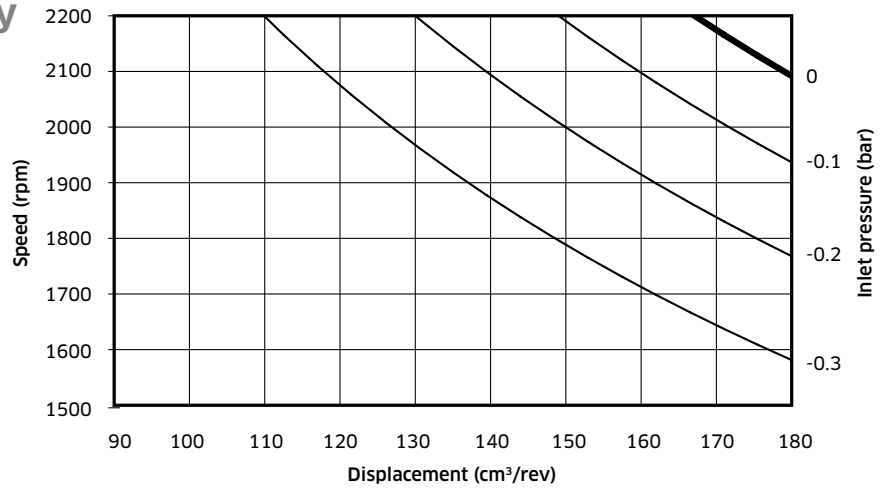

#### Performance Note:

All performance curves are based on the following conditions:

- 1,800 rpm
- ISO VG46 mineral oil
- 50°C oil temperature
- Atmospheric inlet condition (0 bar)

## 2-3 Performance Data (cont)

### K7VG265

#### ◆ Pump Efficiency (%)

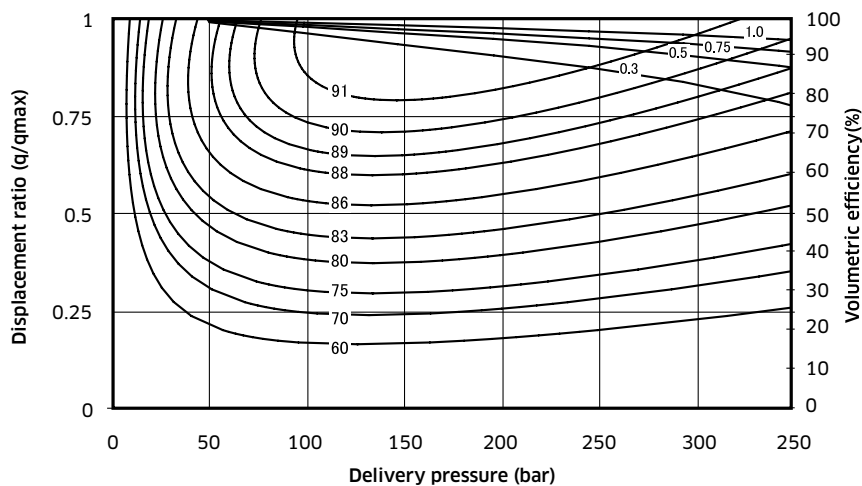

#### ◆ Self Priming Capability

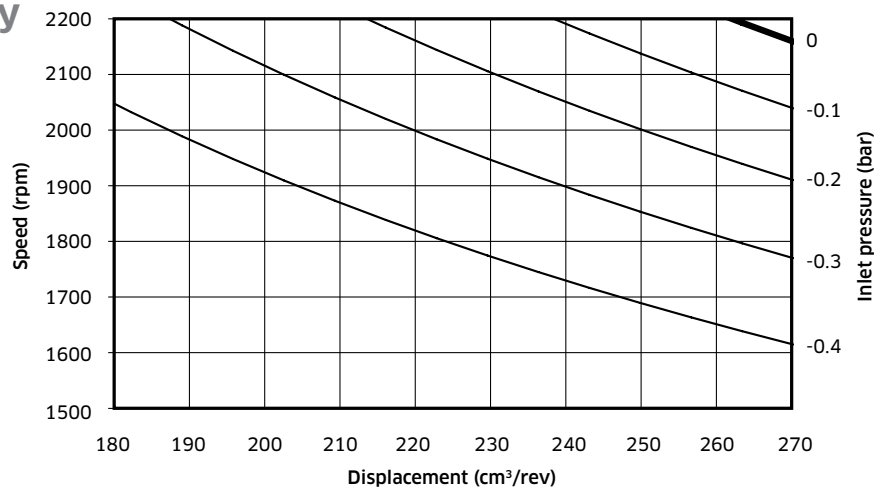

#### Performance Note:

All performance curves are based on the following conditions:

- 1,800 rpm
- ISO VG46 mineral oil
- 50°C oil temperature
- Atmospheric inlet condition (0 bar)

## 2-4 Bearing Life

### ◆ K7VG180

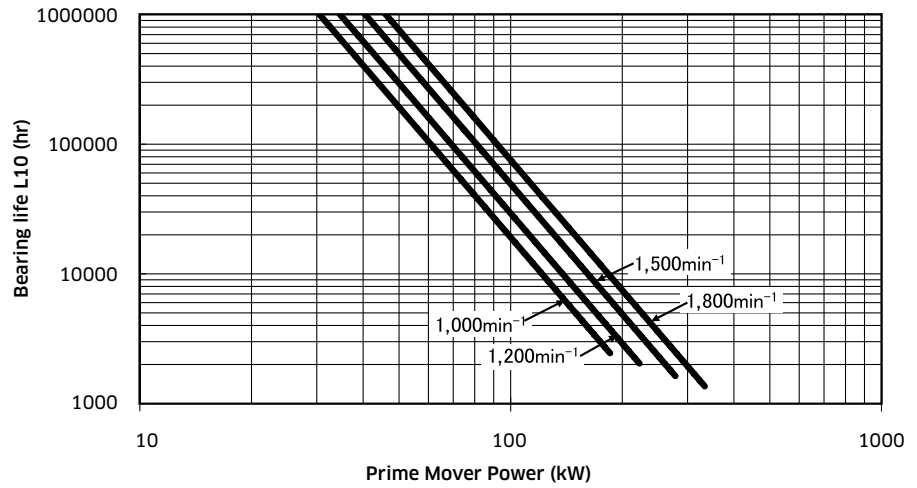

### ◆ K7VG265

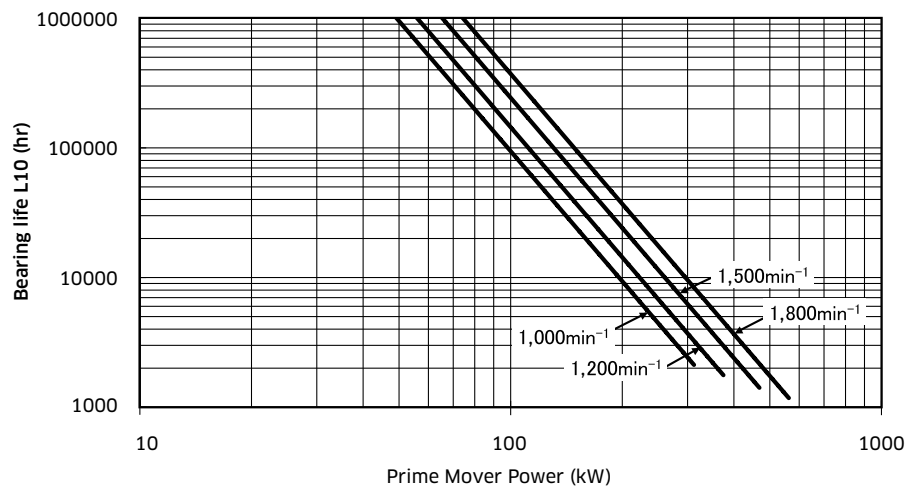

## 2-5 Functional Description of Regulator

### ◆ Boundary Control

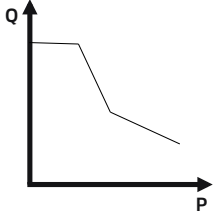
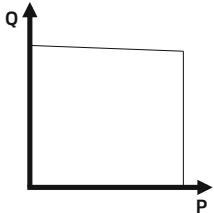
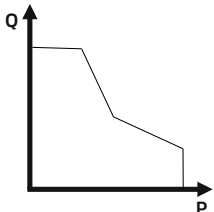
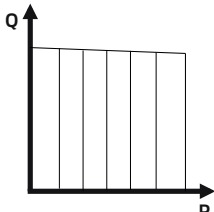
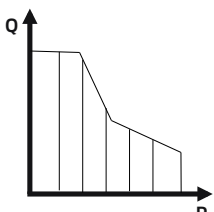
Code	Control Type	Control Curves	Function & Features
1 *	Horsepower control		In response to a rise in delivery pressure, the pump's displacement angle reduces such that its input torque is maintained essentially constant. This function prevents excessive load on the motor driving the pump. There is however no pressure Cut Off function. Be sure to install a safety valve in the circuit.
4 *	Direct Acting Pressure Compensator		Regardless of changes in flow demand, the pump outlet pressure is maintained constant. Be sure to install a safety valve in the circuit.
5 *	Horsepower Control with Direct Acting Pressure Compensation		This regulator combines the functions of a Horsepower control (Type 1) with a direct acting pressure compensator (Type 4). Be sure to install a safety valve in the circuit.
C *	Remote Pressure Compensator		This regulator allows one to remotely control the pump's compensator pressure. Be sure to install a safety valve in the circuit.
D *	Horsepower Control with Remote Pressure Compensation		This regulator adds the function of a Horsepower control (Type 1) to a pilot operated pressure compensator (Type C) that can remotely control the pump's compensator pressure. Be sure to install a safety valve in the circuit.

## 2-5 Functional Description of Regulator (cont)

### ◆ Boundary Control + Load Sensing

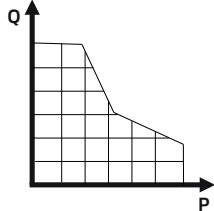
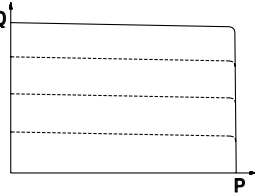
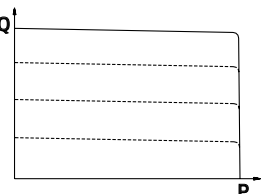
Code	Control Type	Control Curves	Function & Features
<b>7</b> *	Horsepower Control with Load Sensing & Remote Pressure Compensation		This regulator adds the function of a Horsepower control (Type 1) to a load sensing and pressure compensated regulator (Type E). Be sure to install a safety valve in the circuit.
<b>E</b> *	Load Sensing Compensator		This regulator provides the load sensing compensation function. Be sure to install a safety valve in the circuit.
<b>F</b> *	Horsepower Control with Load Sensing Compensation		This regulator adds the function of a Horsepower control (Type 1) to a load sensing compensator (Type E). Be sure to install a safety valve in the circuit.

## 2-5 Functional Description of Regulator (cont)

### ◆ Flow Control

Code	Control Type	Control Curves	Function & Features
0 0	Manual control		The pump is supplied without any regulator fitted. The discharge flow however can be steplessly adjusted by manually turning adjustment screws on the pump up to a maximum of 50% of $q_{max}$ .
* P	Positive Flow Control		<p>Infinitely variable adjustment of pump displacement is possible by application of a hydraulic pressure signal. An increasing pilot pressure results in a proportional increase in pump displacement.</p> <p>Up to 40 bar variable pilot pressure source needs to be provided.</p>
* N	Negative Flow Control		<p>Infinitely variable adjustment of pump displacement is possible by application of a hydraulic pressure signal. A decreasing pilot pressure results in a proportional increase in pump displacement.</p> <p>Up to 40 bar variable pilot pressure source needs to be provided.</p>
* E	Electric Flow Control		<p>Infinitely variable adjustment of pump displacement is possible by application of an electric current to the integrated proportional reducing valve. An increasing current results in a proportional increase in pump displacement.</p> <p>A 40 bar pilot pressure source needs to be provided.</p>

## 2-6 Horsepower Limiter Settings

### ◆ Horsepower set codes

Input Torque	K7VG180				K7VG265			
	970	1150	1450	1750	970	1150	1450	1750
Nm								
30	M4	.	.	-	-	-	-	-
37	M2	M3	.	.	.	-	-	-
45	M0	M2	M4	.	M5	.	-	-
55	H3	M0	M2	M4	M3	M5	.	-
75	-	H1	MA	M1	H3	M1	M4	-
90	-	-	H2	MA	H2	H3	M2	M4
110	-	-	-	H2	-	H1	H4	M2
132	-	-	-	-	-	-	H2	H4

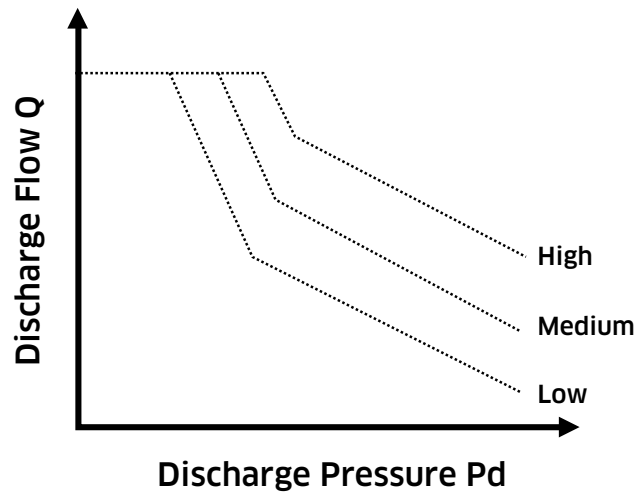

For lower settings please consult KPM UK.



## 2-7 Installation

### ◆ Pump Mounting Options

#### Drain line

It is the preferred option to mount the pump with the case drain piping initially rising above the pump before continuing to the tank. Do not connect the drain line to the inlet line.

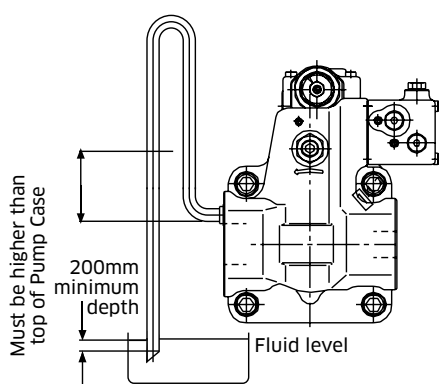

#### Cautions

- A) Inlet and drain pipes must be immersed by 200 mm minimum from the lowest oil level under operating conditions.
- B) Height from the oil level to the centre of the shaft must be within 1 meter maximum. (consult KPM UK).
- C) The oil in the pump case must be refilled when the pump has not been operated for one month or longer.

The uppermost drain port should be used and the drain piping should be equal or larger in size than the drain port to minimise pressure in the pump case. The pump case pressure should not exceed 1 bar as shown in the illustration below. (Peak pressure should never exceed 4 bar.)

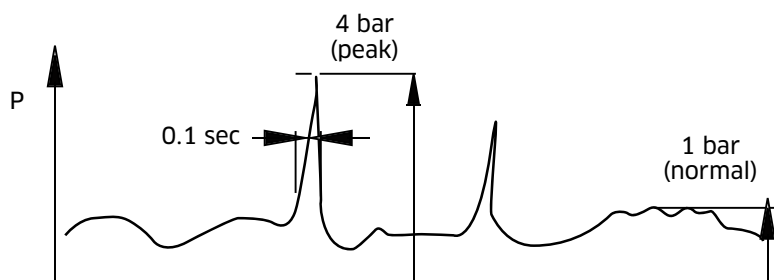

#### Mounting the Pump Above the Tank

##### Suction line

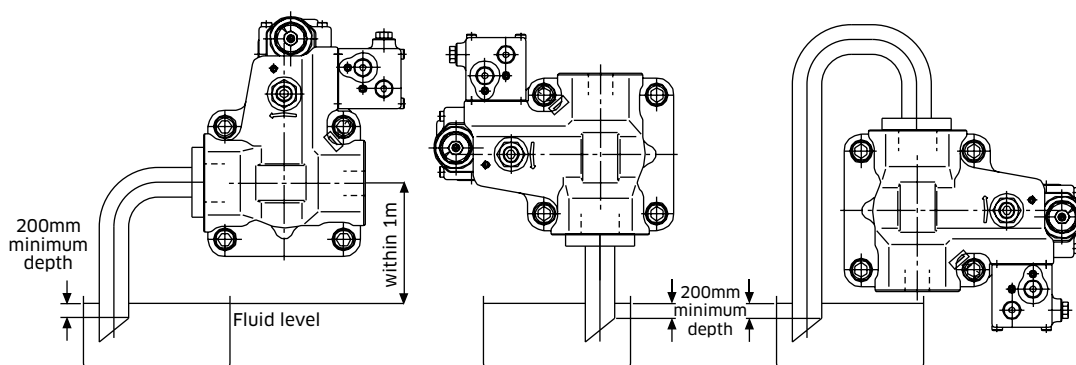

## 2-7 Installation (cont)

### Mounting the Pump Vertically (shaft up)

Note: Both the Tair and one case drain port must be used.

For applications requiring vertical installation (shaft up) please remove the Tair bleed plug and connect piping as shown in the illustration below.

When installing the pump in the tank and submerged in the oil, open the drain port and Tair bleed port to provide adequate lubrication to the internal components. See illustration [a].

The oil level in the tank should be higher than the pump-mounting flange as shown in illustration [a] below. If the oil level in the tank is lower than the pump mounting flange then forced lubrication is required through the Tair bleed port 1 ~ 2 l/min.

When installing the pump outside the tank run piping for the drain and Tair bleed ports to tank (see illustration [c]). If the drain or Tair bleed piping rise above the level of oil (see illustration [b]) fill the lines with oil before operation. motor to your national standard is not exceeded.

