

K3VG Series Axial Piston Pumps Service Manual

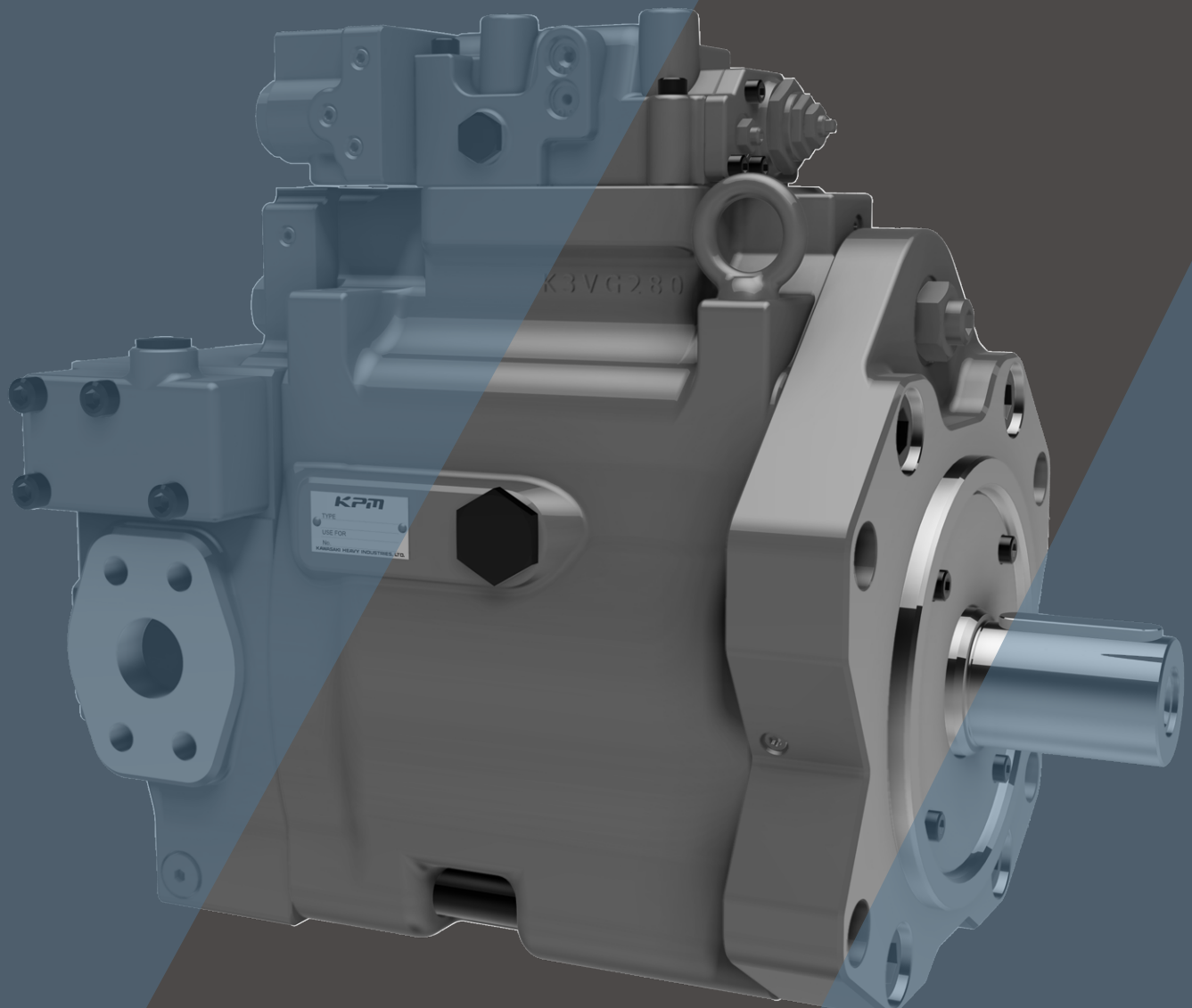

CONTENTS

Applications/Product Usage	3
Safety Precautions	4
Conversion Factors and Formula	5
General Descriptions and Features	7
1. Ordering Code	
1-1. Pump Options	8
1-2. Regulator Options	9
2. Technical Information	
2-1. Technical Data	10 - 12
2-2. Specifications	13
2-3. Functional Description of Regulators	14 - 17
2-4. Power Setting Codes	18 - 19
2-5. Performance Data	20 - 25
2-6. Bearing Life	26 - 27
2-7. Installation	28 - 30

Applications/Product Usage





The following must be taken into consideration before use.

1. The operating condition of the products shown in this catalog varies depending upon each application. Therefore, the product suitability must be judged by the designer of the hydraulic system and/or the person who finalizes the technical specifications of the machine after analysis and testing. The product specification shall be determined based on the latest catalog and technical documents. The system must be designed taking into account the possibility of machine failure to ensure that all safety, warning, and application requirements are met.
2. For the proper use of the products, descriptions given in the SAFETY PRECAUTIONS must be observed.
3. The technical information in this catalog represents typical characteristics and performance of the products as of the published date.
4. If the intended use of the products is included in the following, please consult with Kawasaki in advance.
 - (1) Use the product in the operating conditions or environments other than those described in the technical documents.
 - (2) Use the product in the nuclear sector, aviation sector, medical sector, and/or food sector.
 - (3) Use the product in applications which may cause substantial harm to others and their property, and especially in applications where ensuring safety is a requirement.
5. The information described in this catalog is subject to change without notice. For the latest information, please contact Kawasaki.





Safety Precautions

Before using the product, you **MUST** read this catalog and **MUST** fully understand how to use the product. To use the product safely, you **MUST** carefully read all Warnings and Cautions in this catalog.













1. Cautions related to operation

-  - Use the personal protective equipment to prevent injury when the product is in operation.
-  - Some components are heavy. Handle the product carefully not to hurt your hands and lower back.
-  - Do not step on, hit or drop, or apply strong force to the product, as these actions may cause operation failure, product damage, or oil leakage.
-  - Wipe off any oil on the product or the floor completely, as oil can create slippery conditions that may cause drop of the product and personal injury.

2. Warnings and cautions related to installation and removal of the product

-  - Installation, removal, piping, and wiring must be done by a qualified technician.
-  - Make sure that the hydraulic power unit is turned off and that the electric motor or engine has completely stopped before starting installation or removal. You must also check that the system pressure has dropped to zero.
-  - Make sure that the power source is turned off before installing electric components to reduce the risk of electric shock.
-  - Clean the threads and the mounting surface to prevent damage or oil leakage. Inadequate cleaning may cause insufficient torque and broken seals.
-  - Use the designated bolts and fasten them with prescribed torque when installing the product. Use of undesignated bolts, and excessive or insufficient tightening torque may induce operation failure, damage, or oil leakage.

3. Warnings and cautions for operation

-  - Always equip the product with explosion or ignition protection if it is used in potentially explosive or combustible atmospheres.
 -  - Shield rotary parts, such as the motor and pump shaft, to avoid injury.
 -  - Stop operation immediately, and take proper measures when the abnormality such as unusual noise, oil leakage, and smoke is found. Continuing operation under such condition may bring about damage, a fire hazard, or injury.
 -  - Make sure that all pipes, hoses, and connecting points with pipes or hoses, are correctly connected and tightened before starting operation.
 -  - Use the product under the operating conditions and limitations described in the catalog, drawings, and specification sheets.
 -  - Do not touch the product in operation. to reduce the risk of skin burn.
 -  - Use the proper hydraulic oil and maintain the filtration at the recommended level to prevent premature wear and damage.
- ## 4. Cautions related to maintenance
-  - Never modify the product without approval from Kawasaki.
 -  - Disassembly of the product may void the warranty.
 -  - Keep the product clean and dry when storing or transporting.
 -  - The seals may need to be replaced if the product has been stored for an extended period of time.
 -  - Making adjustments of this product will result in the warranty being null and void.

Conversion Factors and Formula

◆ Conversion Factors

	Formula	Note
Displacement	1 cm ³ = 0.061 in ³	
Pressure	1 MPa = 145 psi	
Flow	1 L/min = 0.264 gpm	US gallon
Torque	1 Nm = 0.74 lbf ft	
Power	1 kW = 1.341 hp	
Weight	1 kg = 2.205 lb	

◆ Formula

	Metric system		Imperial system	
Output flow	$Q = q \times N \times \eta_v / 1000$	L/min	$Q = q \times N \times \eta_v / 231$	gal/min
Input torque	$T = q \times \Delta P / 2\pi / \eta_m$	Nm	$T = q \times \Delta P / 24\pi / \eta_m$	lbf ft
Input power	$L = T \times N / 9550 = Q \times \Delta P / 60 / \eta_t$	kW	$L = T \times N / 5252 = Q \times \Delta P / 1714 / \eta_t$	hp

K3VG Series

Swash Plate Type Axial Piston Pump

■ General Descriptions

The K3VG Series Swash Plate Type Axial Piston Pumps are designed to specifically satisfy the industrial open circuit market where noise, efficiency, controllability and extended pump life are considered to be essential. K3VG Pumps are available in nominal displacements ranging from 3.84 to 34.2 in³/rev (63 to 560 cm³/rev) with various pressure, flow, and combination control options.

Key features of K3VG Pumps include

1. Reliable, High Pressure and Long Life Design

- The K3VG Series Design is based on the K3V Mobile Series Pump where more than 700,000 units have been supplied to the Construction Machinery Market. The K3VG pump incorporates high load bearings and a friction free contacting mechanism for the piston-shoes. This design has resulted in a pump with high reliability and long service life.

2. Low Noise

- The unique, compact and rigid housing construction in addition to the semi-cylindrical pillow type swash-plate and its anti-vibration supporting mechanism has significantly reduced noise levels.

3. High Efficiency and High Self-Priming Capability

- K3VG Pumps encompass a spherical shaped valve plate design and improved hydraulic balancing which provide stable cylinder rotation, thus achieving high efficiency even in low-pressure, low-speed operating conditions. The spherical shaped valve plate also enables a shortened radius of the cylinder ports, which reduces the peripheral velocity and pressure-drop. This feature significantly improves the self-priming capability of the pump.

4. Extensive Range of Control Options

- A large variety of hydromechanical and hydroelectric control methods are available. Displacement, pressure cutoff, horsepower control, and various combinations of these controls are available.

5. Auxiliary Gear Pump

- Various sizes of optional gear pumps can be provided. Therefore, no separate pump unit is necessary as a control pressure source or system medium-pressure source and possible to attach high pressure gear pump. Hydraulic units can thus be made compact and more economical.

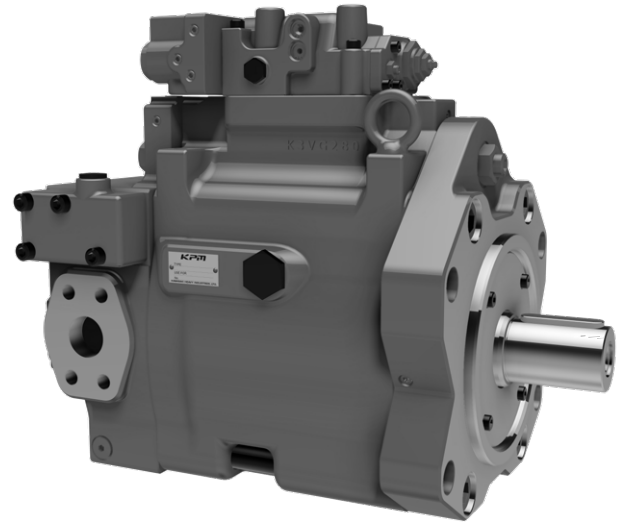

■ Features

Reliable, High Pressure, Long Life Modular Design.

Low Noise and High Efficiency.

Self-Compensating piston return mechanism.

Extensive Range of Highly Responsive Control Options.

Auxiliary Gear Pump Option.

Rated Pressure 350 Bar.

Peak Pressure 400 Bar.

High Continuous Power Rating.

Fully Balanced Spherical Valve Plate.

Infinite displacement control.

Hydrostatically Balanced Swash Plate Support.

High Load Capacity Bearings.

1-1 Pump Options

1	2	3	4	5	6	7	8	9	10	11	12	13	14
K3VG	180DT	-	1	A	0	R	S	V	1E	H1	-S	1	+4

- NOT AVAILABLE ● AVAILABLE

1. K3VG Series Pump

K3VG Series, Variable Displacement, Axial Piston, Open Loop Pump

63	112	180	280	180DT	280DT
----	-----	-----	-----	-------	-------

2. Pump Size

Maximum Displacement	in ³ /rev	3.84	6.83	11.0	17.1	22.0	34.2
	cm ³ /rev	63	112	180	280	360	560

3. Hydraulic Fluid Type

-	Mineral Oil	●	●	●	●	●	●
W	Water Glycol	●	●	●	●	●	●
P	Polyol Ester	●	●	●	●	●	●

4. Circuit Type

1	Open Circuit	●	●	●	●	●	●
---	--------------	---	---	---	---	---	---

5. Attached Gear Pump

0	Without gear pump	●	●	●	●	●	●
1	10 cm ³ gear pump with built-in relief valve, set pressure 580psi	●	●	●	●	●	●
2	15 cm ³ gear pump with built-in relief valve, set pressure 580psi	●	●	●	●	●	●
3	Without gear pump, with assistant cover (only single pump)	●	●	●	●	-	-
4-9,C-F	High-pressure gear pump can be attached	●	●	●	●	-	-
A	High-pressure gear pump can be attached	-	-	-	●	●	●

6. Mounting Bracket/Port Flange

0	Without bracket, With flange	●	●	●	●	●	●
F	With bracket, With flange	●	●	●	●	●	●
B	With bracket, Without flange	●	●	●	●	●	●
N	Without bracket, without flange	●	●	●	●	●	●

7. Hydraulic Fluid Type

R	Clockwise Rotation	●	●	●	●	●	●
L	Counter Clockwise Rotation	-	-	-	-	●	●

8. Design Code

S	Design code	●	●	●	●	●	●
---	-------------	---	---	---	---	---	---

9. Direction of Mounting

-	Standard (horizontal mounting)	●	●	●	●	●	●
V	Vertical mounting	●	●	●	●	●	●

12. Confluent block (Only tandem type)

Blank	Single pump	●	●	●	●	-	-
-0	Without confluent block	-	-	-	-	●	●
-S	Side outlet type	-	-	-	-	●	●
-R	Rear outlet type	-	-	-	-	●	●

13. Auxiliary pump unit (Only tandem type)

Blank	Without auxiliary pump unit	●	●	●	●	-	-
1	With auxiliary gear pump unit (Only tandem type, clockwise type, and attached gear pump code 'A')	-	-	-	-	●	●

14. Auxiliary pump unit

Blank	Without resonator	●	●	●	●	●	●
+4	With resonator for 1,000-1,200 rpm	●	●	●	●	●	●
+6	With resonator for 1,500-1,800 rpm	●	●	●	●	●	●

1-2 Regulator Options

1	2	3	4	5	6	7	8	9	10	11	12	13	14
K3VG	180DT	-	1	A	0	R	S	V	1E	H1	-S	1	+4

63	112	180	280	180DT	280DT
----	-----	-----	-----	-------	-------

10. Pump Control Options

	Pressure (horsepower) Control	Flow Control						
00	No pressure (horsepower) control	Manual control	●	●	●	●	●	●
0P	No pressure (horsepower) control	Positive flow control	●	●	●	●	●	●
0N	No pressure (horsepower) control	Negative flow control	●	●	●	●	●	●
0E	No pressure (horsepower) control	Electric flow control	●	●	●	●	●	●
10	Horsepower control	Manual control	●	●	●	●	●	●
1P	Horsepower control	Positive flow control	●	●	●	●	●	●
1N	Horsepower control	Negative flow control	●	●	●	●	●	●
1E	Horsepower control	Electric flow control	●	●	●	●	●	●
40	Pressure constant (compensated)	Manual control	●	●	●	●	●	●
4L	Pressure constant (compensated)	Load sense	●	●	●	●	●	●
50	Horsepower and pressure constant	Manual control	●	●	●	●	●	●
5P	Horsepower and pressure constant	Positive flow control	●	●	●	●	●	●
5N	Horsepower and pressure constant	Negative flow control	●	●	●	●	●	●
5E	Horsepower and pressure constant	Electric flow control	●	●	●	●	●	●
60*	Pressure constant (compensated)	Manual control	●	●	●	●	●	●
6L*	Pressure constant (compensated)	Load sense	●	●	●	●	●	●
70	Horsepower and pressure constant	Manual control	●	●	●	●	●	●
7P	Horsepower and pressure constant	Positive flow control	●	●	●	●	●	●
7N	Horsepower and pressure constant	Negative flow control	●	●	●	●	●	●
7E	Horsepower and pressure constant	Electric flow control	●	●	●	●	●	●
7L	Horsepower and pressure constant	Load sense	●	●	●	●	●	●

11. Horsepower Set Code

00	No horsepower control (only for control option*)	●	●	●	●	●	●
H#	High setting range	●	●	●	●	●	●
M#	Medium setting range	●	●	●	●	●	●
L#	Low setting range	●	●	●	●	●	●

*Non standard Options - Contact KPM

2-1 Technical Data

For applications outside the following parameters, please consult KPM.

◆ Hydraulic Data

Pressure Fluid Mineral oil, polyol ester and water glycol.

Use a high quality, anti-wear, mineral based hydraulic fluid when the pressure exceeds 210 bar. In applications where fire resistant fluids are required consult KPM.

◆ Fluid selection

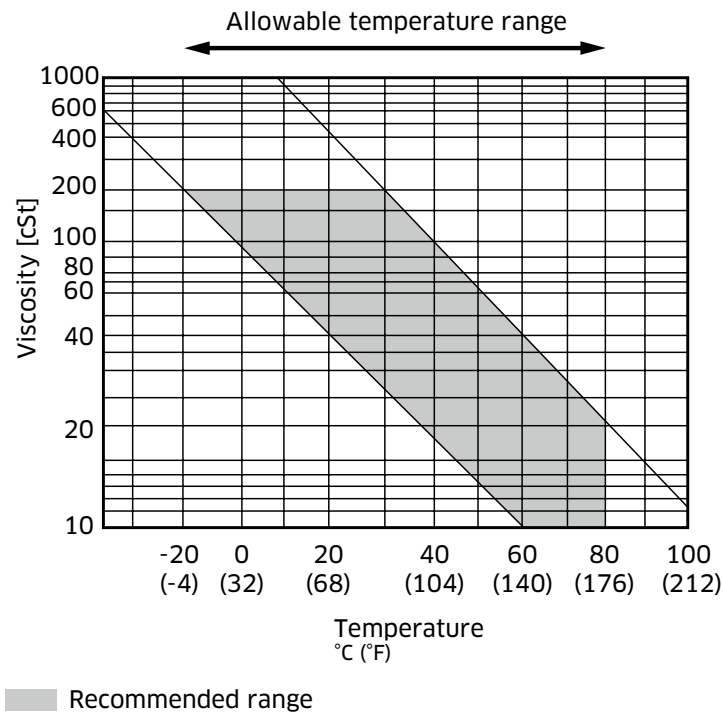

2-1 Technical Data (cont)

◆ Filtration & Contamination Control

Filtration

The most important means to prevent premature damage to the pump and associated equipment and to extend its working life, is to ensure that hydraulic fluid contamination control of the system is working effectively.

This begins by ensuring that at the time of installation that all piping, tanks etc. are rigorously cleaned in a sanitary way. Flushing should be provided using an off line filtration system and after flushing the filter elements should be replaced.

A full flow return line filter of 10 micron nominal should be utilised to prevent contaminant ingress from the external environment, a 5 to 10 micron filter within the tank's breather is also recommended.

◆ Suggested Acceptable Contamination Level

The relationship between contamination level and pump life is very difficult to predict as it depends on the type and nature of the contaminant present in the system. Sand or Silica in particular, due to its abrasive nature, does significantly reduce the expected life of a pump. Based on the precondition that there is no significant presence of Silica type substances then a minimum Cleanliness level of -/18/15 ISO 4406 or SAE AS 4059E Table 1 Class 9 (NAS 1638 Class 9).

◆ Working Fluid Types

Anti-Wear Type Hydraulic fluid

It is generally recommended to use an anti-wear hydraulic fluid like mineral oil when the operating pressure exceeds 210 bar.

Fire-resistant Fluids

Some kind of fire-resistant fluids require special materials for seals, paint and metal finishing. Please consult KPM and provide details of the particular fluid specification and the working conditions so that any special requirements can be ascertained.

In general, fire-resistant fluids have a low viscosity index and their viscosity also changes significantly with operating temperature and service life. For this reason, the circuit should be provided with an adequately sized cooler or forced cooling so that temperatures can be stabilised. Due to the inherent water content of some of these fluids the minimum allowable suction pressure will be higher than that of an equivalent mineral oil and so needs to be fully evaluated by KPM. The following table provides an overview of the precautions and characteristics that can be expected with these types of fluids.

Fluid Type Parameter	Mineral Oil	Polyol Ester	Water Glycol
Maximum Pressure psi(bar)	5,075 (350)	5,075 (350)	3,045 (210)
Recommended Temperature Range F(C)	68 - 140 (20 - 60)	68 - 140 (20 - 60)	50 - 122 (10 - 50)
Cavitation susceptibility	○	△	△
Life expectancy compared to mineral oil	100%	50 - 100%	20 - 80%

○ recommended △ usable (higher density)

2-1 Technical Data (cont)

Pump Start Up Precautions

Pump Case Filling

Be sure to fill the pump casing with oil through the drain port, filling only the suction line with oil is totally insufficient. The pump contains bearings and high-speed sliding parts including pistons with shoes and spherical bushes that need to be continuously lubricated. Part seizure or total premature failure will occur very quickly if this procedure is not rigidly followed.

Piping & Circuit Checking

Check to see that the piping and full hydraulic circuit is completed and that any gate valves etc. are open.

Direction of Rotation

Check to ensure that direction of rotation is correct and that the inlet and delivery lines are connected correctly.

Start Up

Jog start the motor and check once more for correct rotation. Run the pump unloaded for a period to ensure that all residual air within the system is released. Check for external leakage, abnormal noise and vibrations.

Case Drain Pressure

Please ensure, that the maximum steady state drain line pressure at the pump casing does not exceed 1 bar. (Maximum peak pressure 4 bar). A suitable drain line hose must be selected and return directly back to the tank and terminate below the oil level.

Long Term Out of Usage

It is undesirable to leave the pump out of use for a long period e.g. a year or more. In such a situation it is recommended that the pump is run for a short period on a more frequent basis even if it is just unloaded. With regard to a pump held in storage then rotating the shaft on a frequent basis is sufficient. If the pump is left out for more than the suggested time it will require a service inspection.

2-2 Specifications

For applications outside of the following parameters please contact KPM.

Pump Model		K3VG63	K3VG112	K3VG180	K3VG280	K3VG180DT	K3VG280DT
Displacement	in ³ (cm ³ /rev)	3.84 (63)	6.83 (112)	11.0 (180)	17.1 (280)	22.0 (360)	34.2 (560)
Rated Pressure ⁽¹⁾	psi (bar)	5,075 (350)					
Peak Pressure ⁽²⁾	psi (bar)	5,800 (400)					
Maximum Self Priming Speed ⁽³⁾	rpm	2,600	2,200	1,850	1,600 ⁽⁵⁾	1,850	1,600 ⁽⁵⁾
Maximum Boosted Speed ⁽⁴⁾	rpm	3,250	2,700	2,300	2,000	2,300	2,000
Weight	lb (kg)	106 (48)	150 (68)	190 (86)	353 (160)	353 (160)	661 (300)

⁽¹⁾ Consult bearing life charts for high horsepower applications. Please contact Kawasaki for application assistance.

⁽²⁾ Maximum allowable safety relief valve setting.

⁽³⁾ Steady State Suction Pressure \geq -1.45 psi (-2.95 in Hg), (-0.1 bar)

⁽⁴⁾ Minimum Recommended Boost Pressure at Suction Port \geq 14.5 psi (29.52 in Hg), (1 bar)

⁽⁵⁾ Precautions must be taken when operating the K3VG280/DT at 1800 rpm.

In order to prevent damage to the pump:

Suction Pressure	Maximum Displacement
+7.1psi (+0.5bar)	280cc/rev
+1.4psi (+0.1bar)	250cc/rev
-1.4psi (-0.1bar)	232cc/rev

2-3 Functional Description of Regulators

Key to Hydraulic Circuit Annotations	
Annotation	Description
A , A ₁	Main pump delivery
A ₂	Auxiliary pump delivery
a , a ₁	Gauge port main pump delivery
a ₂	Gauge port auxiliary pump delivery
B , B ₁	Main pump suction
B ₂	Gear pump suction
b	Suction gauge port
Dr	Drain
P _i	Pilot pressure
P _c	Remote pilot port, pressure compensator
P _L	Load sense port
P _{sv}	Pressure assist port

Note: The optional attached gear pump is recommended for all displacement control options. Hydraulic circuit diagrams illustrate the attached gear pump.

2-3 Functional Description of Regulators (cont)

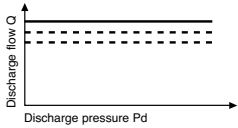
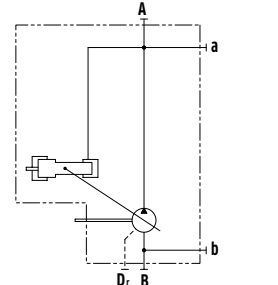
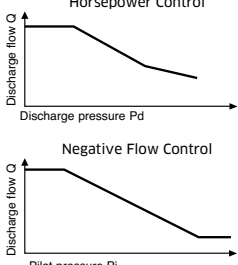
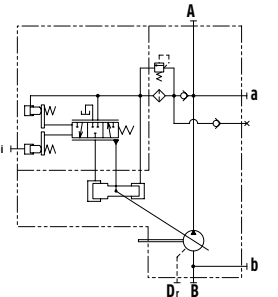
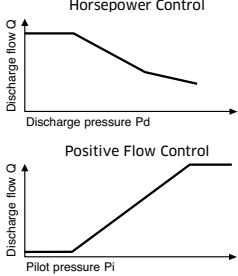
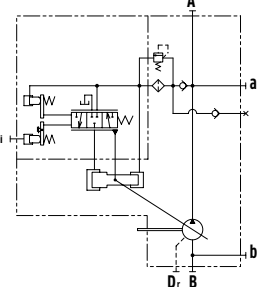
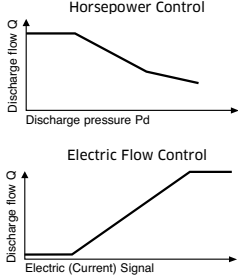
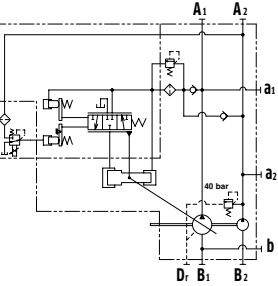
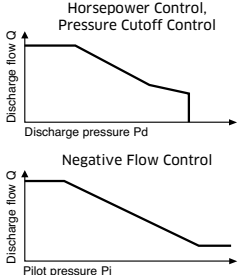
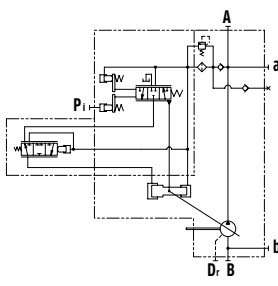
Regulator Code	Control Curves	Hydraulic Circuit
<p>0000 Stepless Manual Displacement Control The pump is supplied without a regulator. The discharge flow can be steplessly adjusted by manually turning adjustment screws on the pump. This adjustment provision is a standard feature on all K3VG pumps providing a means to limit the maximum and minimum displacement.</p>	 <p>Range of Flow Control 50-100%</p>	
<p>10## Horsepower Control 1N## Horsepower and Negative Flow Control In response to a rise in delivery pressure, the swash plate tilting angle is decreased, restricting the input torque. This regulator prevents excessive load against the prime mover. By adding a pilot signal to the Pi port the discharge flow can be infinitely adjusted within the range of the pump. An increase in pilot signal will result in a decrease in flow, hence the Negative control.</p>	 <p>Range of Flow Control 100-2.5%</p>	
<p>1P## Horsepower and Positive Flow Control This regulator combines the Horsepower Control with Positive Flow Control. By adding a pilot signal to the Pi port the discharge flow can be infinitely adjusted within the range of the pump. An increase in pilot signal will result in an increase in flow, hence the Positive control.</p>	 <p>Range of Flow Control 2.5-100%</p>	
<p>1E## Horsepower and Electric Flow Control This regulator combines the Horsepower Control with Electric Flow Control. A proportional reducing valve is added to the regulator so the discharge flow can be infinitely adjusted within the range of the pump. An increase in electric signal to the proportional reducing valve will result in an increase in flow. This regulator requires an amplifier (refer to page9) to provide the electric signal.</p>	 <p>Range of Flow Control 2.5-100%</p>	
<p>50## Horsepower and Pressure Cutoff 5N## Horsepower, Pressure Cutoff and Negative Flow Control This regulator combines the Horsepower Control with Pressure Cutoff Control. By adding a pilot signal to the Pi port the discharge flow can be infinitely adjusted within the range of the pump. An increase in pilot signal will result in a decrease in flow, hence the Negative control.</p>	 <p>Range of Flow Control 100-2.5%</p>	

2-3 Functional Description of Regulators (cont)

Regulator Code	Control Curves	Hydraulic Circuit
<p>5P## Horsepower, Pressure Cutoff and Positive Flow Control</p> <p>This regulator combines the Horsepower Control with Pressure Cutoff Control. By adding a pilot signal to the Pi port the discharge flow can be infinitely adjusted within the range of the pump. An increase in pilot signal will result in an increase in flow, hence the Positive control.</p>	<p>Horsepower Control, Pressure Cutoff Control</p> <p>Discharge flow Q</p> <p>Discharge pressure Pd</p> <p>Positive Flow Control</p> <p>Pilot pressure Pi</p> <p>Range of Flow Control 2.5-100%</p>	<p>A</p> <p>a</p> <p>b</p> <p>D, B</p>
<p>5E## Horsepower, Pressure Cutoff and Electric Flow Control</p> <p>This regulator combines the Horsepower Control with Pressure Cutoff and Electric Flow Control. A proportional reducing valve is added to the regulator so the discharge flow can be infinitely adjusted within the range of the pump. An increase in electric signal to the proportional reducing valve will result in an increase in flow. This regulator requires an amplifier (refer to page 9) to provide the electric signal.</p>	<p>Horsepower Control, Pressure Cutoff Control</p> <p>Discharge flow Q</p> <p>Discharge pressure Pd</p> <p>Electric Flow Control</p> <p>Electric (Current) Signal</p> <p>Range of Flow Control 2.5-100%</p>	<p>A₁ A₂</p> <p>a₁ a₂</p> <p>b</p> <p>D, B₁ B₂</p>
<p>5L## Horse power and Load Sense Control</p> <p>This regulator combines Horsepower Control and Load Sense Control.</p>	<p>Discharge flow Q</p> <p>Discharge pressure Pd</p> <p>Range of Flow Control 2.5-100%</p>	<p>A</p> <p>a</p> <p>b</p> <p>D, B</p>
<p>4000 Pressure Cutoff Control</p> <p>This regulator maintains a constant pressure regardless of the discharge flow. It is imperative that a safety relief valve is installed in the circuit.</p> <p>By connecting the Pc port to a remote pressure control, variable pump pressure control can be achieved.</p> <p>A subplate can be added to the regulator that will accommodate a proportional relief valve for variable Pressure Cutoff Control.</p>	<p>Discharge flow Q</p> <p>Discharge pressure Pd</p>	<p>P_c</p> <p>A</p> <p>a</p> <p>b</p> <p>T_{air}</p> <p>D, B</p>
<p>4L00 Load Sense Control</p> <p>This regulator controls the pump displacement to match the flow requirement as a function of load pressure. In addition, there is a Pressure Cutoff Function incorporated into the regulator.</p>	<p>Discharge flow Q</p> <p>Discharge pressure Pd</p> <p>Range of Flow Control 2.5-100%</p>	<p>P_c</p> <p>A</p> <p>a</p> <p>b</p> <p>D, B</p>

2-3 Functional Description of Regulators (cont)

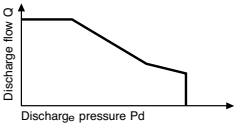
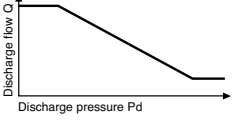
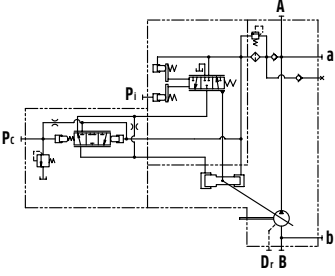
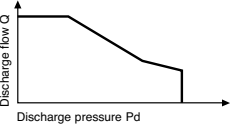
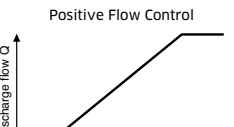
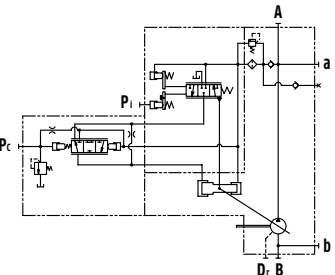
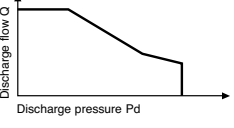
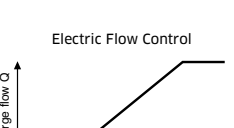
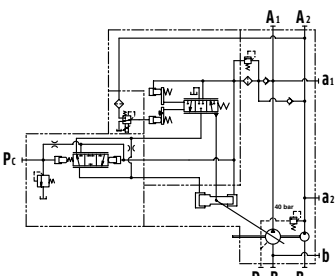
Regulator Code	Control Curves	Hydraulic Circuit
<p>70## Horsepower and Pressure Cutoff 7N## Horsepower, Pressure Cutoff and Negative Flow Control Negative Flow Control (with Remote Pressure Cutoff Capabili This regulator combines the Horsepower Control with Press Cutoff Control. By adding a pilot signal to the Piport the discharge flow can be infinitely adjusted within the range of the pump. An increase in pilot signal will result in a decrease in flow, hence the Negative control.</p> <p>By connecting the Pc port to a rem ote pressure control, variable pump pressure control can be achieved.</p> <p>A subplate can be added to the regulator that will accommodate a proportional relief valve for variable Pressure Cutoff Control.</p>	<p>Horsepower Control, Pressure Cutoff Control</p>   <p>Range of Flow Control 100-2.5%</p>	
<p>7P## Horsepower, Pressure Cutoff and Positive Flow Control (with Remote Pressure Cutoff Capability) This regulator combines the Horsepower Control with Pressur Cutoff Control. By adding a pilot signal to the Pi port the discharge flow can be infinitely adjusted within the range of the pump. An increase in pilot signal will result in an increase in flow, hence the Positive control.</p> <p>By connecting the Pc port to arem ote pressure control, variable pump pressure control can be achieved.</p> <p>A subplate can be added to the regulator that will accommodate a proportional relief valve for variable Pressure Cutoff Control.</p>	<p>Horsepower Control, Pressure Cutoff Control</p>  <p>Positive Flow Control</p>  <p>Range of Flow Control 2.5-100%</p>	
<p>7E## Horsepower, Pressure Cutoff and Electric Flow Control (with Remote Pressure Cutoff Capability) This regulator combines the Horsepower Control with Pressure Cutoff and Electric Flow Control. A proportional reducing valve is added to the regulator so the discharge flow can be infinitely adjusted within the range of the pump. An increase in electric signal to the proportional reducing valve will result in an increase in flow. This regulator requires an amplifier (refer to page 9) provide the electric signal.</p> <p>By connecting the Pc port to a remote pressure control, variable pump pressure control can be achieved.</p> <p>A subplate can be added to the regulator that will accommodatea proportional relief valve for variable Pressure Cutoff Control.</p>	<p>Horsepower Control, Pressure Cutoff Control</p>  <p>Electric Flow Control</p>  <p>Range of Flow Control 2.5-100%</p>	

2-4 Power Setting Codes

HORSEPOWER SET CODES

Standard Regulator at 1200 rpm

Motor Power		K3VG Pump Frame Size					
hp	(kw)	63	112	180	280	180DT	280DT
15	(11.2)	L2	-	-	-	-	-
20	(14.9)	M2	-	-	-	-	-
25	(18.6)	H5	M4	-	-	-	-
30	(22.4)	H3	M1	-	-	-	-
40	(29.8)	-	H4	L1	-	-	-
50	(37.3)	-	H2	M3	-	-	-
60	(44.7)	-	-	M2	L2	-	-
75	(55.9)	-	-	H5	M3	L3	-
100	(74.6)	-	-	H1	M2	M3	L4
125	(93.2)	-	-	-	H5	M1	L2
150	(111.9)	-	-	-	H1	H3	M4
200	(149.1)	-	-	-	-	HA	MA
250	(186.4)	-	-	-	-	-	H5
300	(223.7)	-	-	-	-	-	H2

Example:

Pump: K3VG112-10NR-10??
 Electric Motor: 50hp at 1800 rpm
 Horsepower Set Code: M3
 Final Model Code: K3VG112-10NR-10M3

Standard Regulator at 1500 rpm

Motor Power		K3VG Pump Frame Size					
hp	(kw)	63	112	180	280	180DT	280DT
15	(11.2)	L4	-	-	-	-	-
20	(14.9)	L1	-	-	-	-	-
25	(18.6)	M2	-	-	-	-	-
30	(22.4)	M1	L3	-	-	-	-
40	(29.8)	H2	M3	L3	-	-	-
50	(37.3)	-	M1	L1	-	-	-
60	(44.7)	-	H5	M4	-	-	-
75	(55.9)	-	H3	M2	L2	-	-
100	(74.6)	-	-	H4	M4	L2	-
125	(93.2)	-	-	H2	M2	M4	-
150	(112)	-	-	-	H4	M2	L3
200	(149)	-	-	-	-	H4	MB
250	(186.4)	-	-	-	-	HA	MA
300	(224)	-	-	-	-	-	HA
350	(261)	-	-	-	-	-	HB

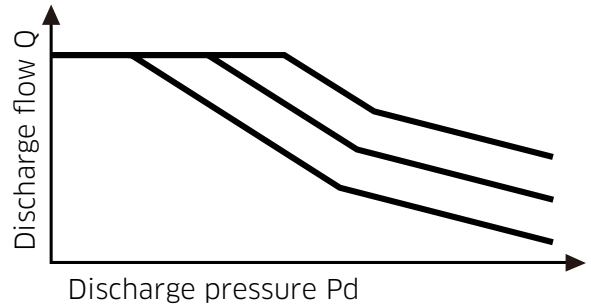

Standard Regulator at 1800 rpm

Motor Power		K3VG Pump Frame Size					
hp	(kw)	63	112	180	280	180DT	280DT
20	(14.9)	L3	-	-	-	-	-
25	(18.6)	L1	-	-	-	-	-
30	(22.4)	M2	-	-	-	-	-
40	(29.8)	H4	L1	-	-	-	-
50	(37.3)	H2	M3	L3	-	-	-
60	(44.7)	-	M1	L1	-	-	-
75	(55.9)	-	H5	M4	-	-	-
100	(74.6)	-	H1	M1	L1*	L4	-
125	(93.2)	-	-	H4	M4*	L2	-
150	(111.9)	-	-	H2	M2*	M4	-
200	(149.1)	-	-	-	HA*	MA	LA*
250	(186.4)	-	-	-	-	HB	MB*
300	(223.7)	-	-	-	-	HA	MA*
350	(261.0)	-	-	-	-	-	HA*
400	(298.3)	-	-	-	-	-	H4*
450	(335.6)	-	-	-	-	-	H2*

*See precaution for operating K3VG280 and K3VG280DT at 1800 rpm on page 1.

2-4 Power Setting Codes (cont)

HORSEPOWER ADJUSTMENT RANGE

The horsepower setting can be adjusted via external adjusting screws. The adjustment range of each horsepower control mode is given in the tables below.

K3VG63

Horsepower control mode		1200rpm hp (kW)	1500rpm hp (kW)	1800rpm hp (kW)
H	High horsepower	23.5 - 35.9 (17.5 - 26.8)	29.5 - 45.3 (22.0 - 33.8)	35.6 - 54.7 (26.6 - 40.8)
M	Medium horsepower	16.6 - 23.9 (12.4 - 17.8)	20.9 - 30.0 (15.6 - 22.4)	25.3 - 36.3 (18.9 - 27.1)
L	Low horsepower	11.3 - 20.1 (8.4 - 15.0)	14.2 - 25.3 (10.6 - 18.9)	17.2 - 30.6 (12.8 - 22.8)

K3VG112

Horsepower control mode		1200rpm hp (kW)	1500rpm hp (kW)	1800rpm hp (kW)
H	High horsepower	39.3 - 33.1 (29.3 - 49.3)	49.6 - 83.2 (37.0 - 62.1)	59.8 - 100.5 (44.6 - 75.0)
M	Medium horsepower	28.8 - 48.4 (21.5 - 36.1)	36.3 - 61.1 (27.1 - 45.6)	43.8 - 73.7 (32.7 - 55.0)
L	Low horsepower	20.2 - 32.6 (15.1 - 24.3)	25.6 - 41.2 (19.1 - 30.7)	30.8 - 49.6 (23.0 - 37.0)

K3VG180

Horsepower control mode		1200rpm hp (kW)	1500rpm hp (kW)	1800rpm hp (kW)
H	High horsepower	59.4 - 102.5 (43.6 - 76.5)	73.7 - 129.3 (55.0 - 96.5)	89.0 - 156.0 (66.4 - 116.4)
M	Medium horsepower	46.6 - 79.8 (34.8 - 59.5)	58.8 - 100.5 (43.9 - 75.0)	71.0 - 121.3 (53.0 - 90.5)
L	Low horsepower	31.8 - 48.4 (23.7 - 36.1)	40.1 - 61.1 (29.9 - 45.6)	48.4 - 73.7 (36.1 - 55.0)

K3VG280

Horsepower control mode		1200rpm hp (kW)	1500rpm hp (kW)	1800rpm hp (kW)
H	High horsepower	95.7 - 159.6 (71.4 - 119.1)	120.6 - 201.2 (90.0 - 150.1)	180.0 - 220.0 (134.3 - 164.0)
M	Medium horsepower	71.6 - 120.6 (53.4 - 90.0)	90.2 - 152.1 (67.3 - 113.5)	120.0 - 180.0 (89.5 - 134.3)
L	Low horsepower	49.7 - 79.7 (37.1 - 59.5)	62.7 - 100.5 (46.8 - 75.0)	80.0 - 125.0 (59.7 - 93.3)

K3VG180DT

Horsepower control mode		1200rpm hp (kW)	1500rpm hp (kW)	1800rpm hp (kW)
H	High horsepower	116.2 - 205.1 (86.7 - 153.0)	146.6 - 258.5 (109.4 - 192.9)	176.9 - 312.2 (132.0 - 232.9)
M	Medium horsepower	93.4 - 143.0 (69.7 - 106.7)	117.8 - 180.3 (87.9 - 134.5)	142.1 - 217.7 (106.0 - 162.4)
L	Low horsepower	63.7 - 96.9 (47.5 - 72.3)	80.3 - 122.1 (59.9 - 91.1)	96.9 - 147.4 (72.3 - 110.0)

K3VG280DT

Horsepower control mode		1200rpm hp (kW)	1500rpm hp (kW)	1800rpm hp (kW)
H	High horsepower	209.8 - 319.1 (156.5 - 238.1)	264.4 - 402.5 (197.3 - 300.3)	290.0 - 450.0 (216.0 - 335.0)
M	Medium horsepower	145.8 - 254.3 (108.8 - 189.7)	183.9 - 320.6 (137.2 - 239.2)	240.0 - 310.0 (179.0 - 231.0)
L	Low horsepower	99.5 - 170.1 (74.2 - 126.9)	125.3 - 214.5 (93.5 - 160.0)	160.0 - 245.0 (119.0 - 183.0)

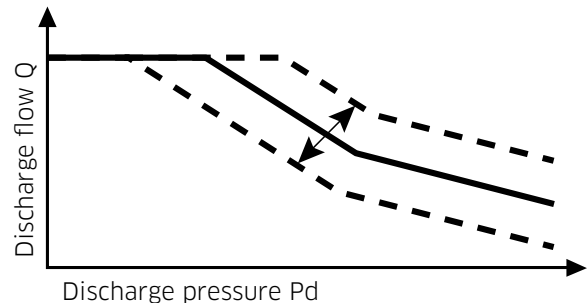

2-5 Performance Data

◆ K3VG63 - Overall Efficiency (%)

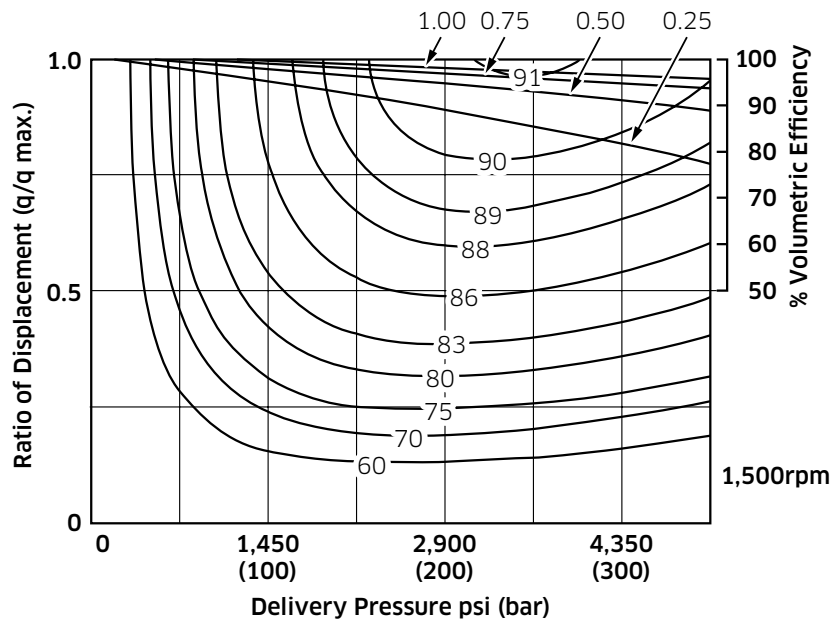

◆ K3VG112 - Overall Efficiency (%)

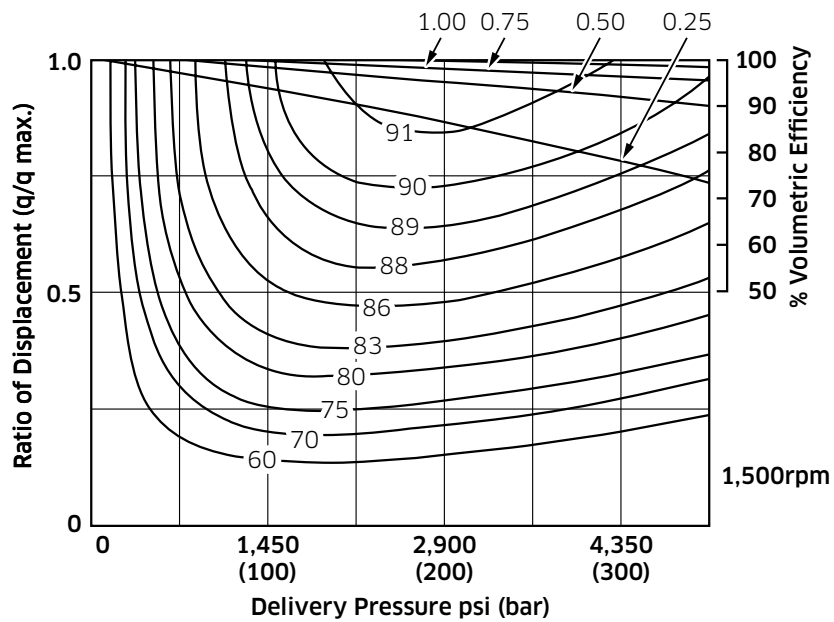

2-5 Performance Data (cont)

◆ K3VG180 and K3VG180DT - Overall Efficiency (%)

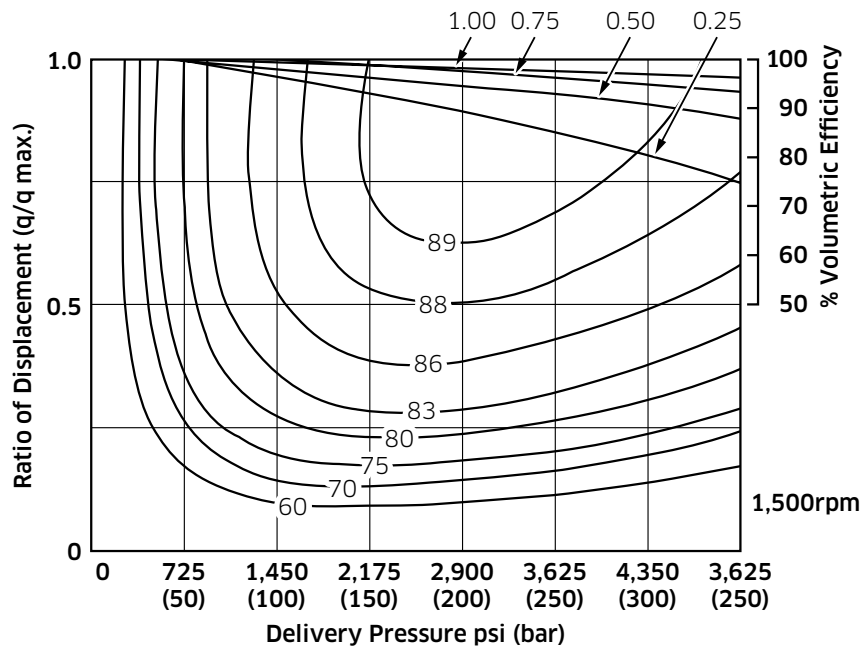

◆ K3VG280 and K3VG280DT - Overall Efficiency (%)

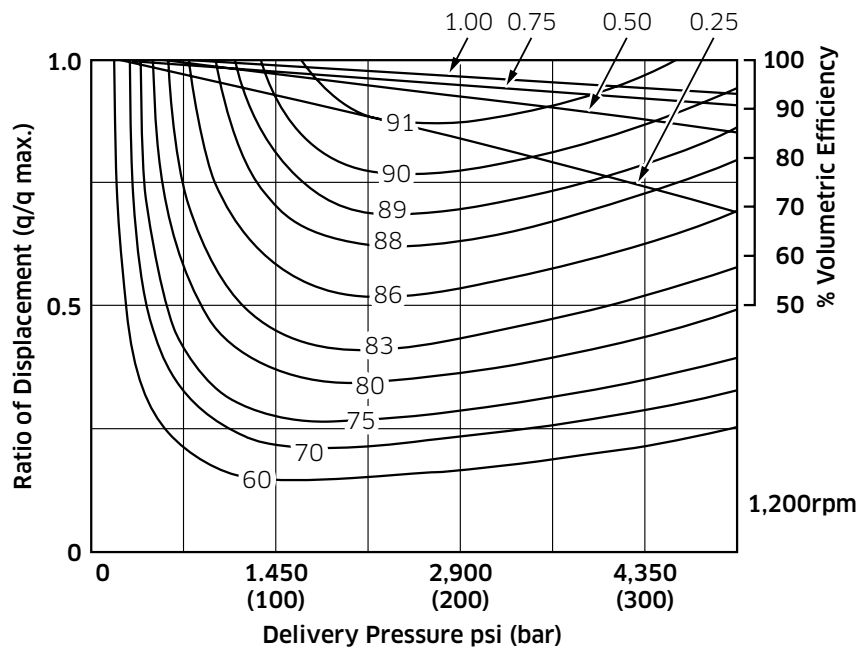

2-5 Performance Data (cont)

Displacement Control Curves

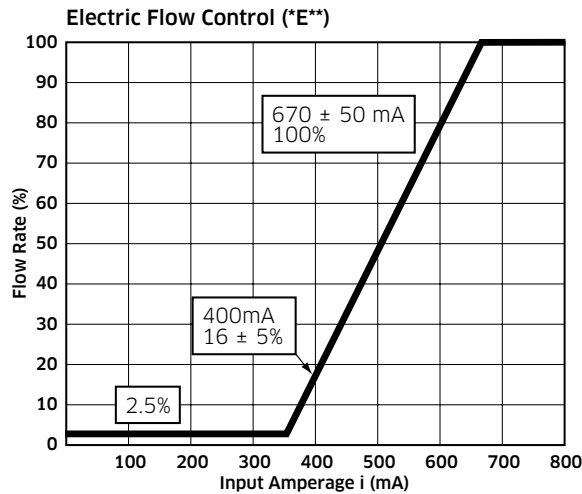
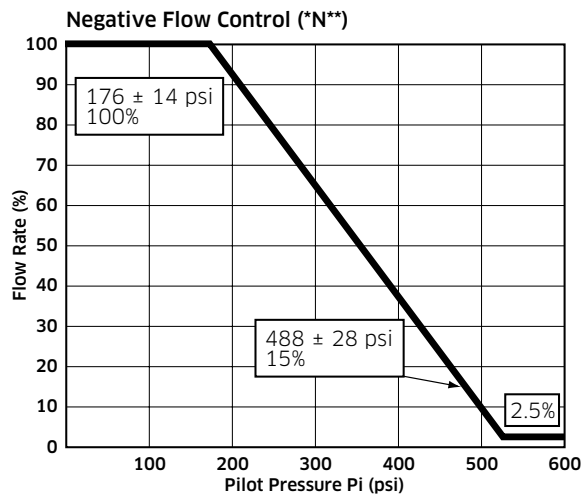
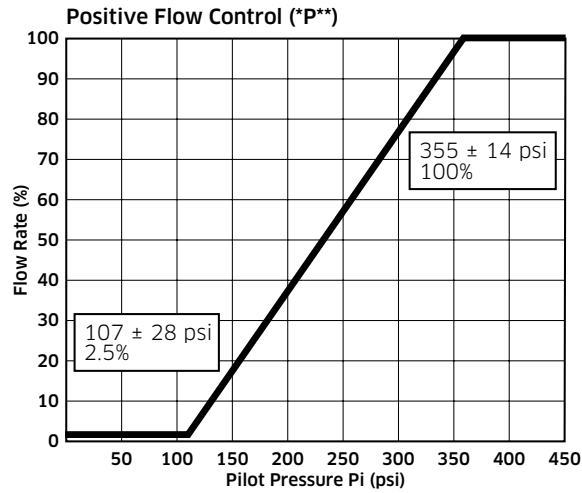

2-5 Performance Data (cont)

Displacement Control Curves

◆ K3VG112

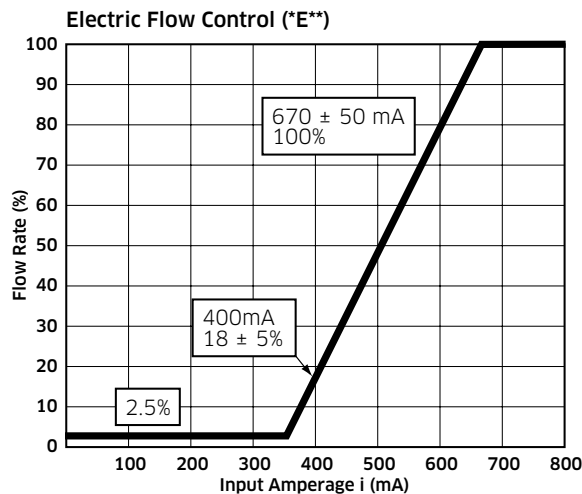
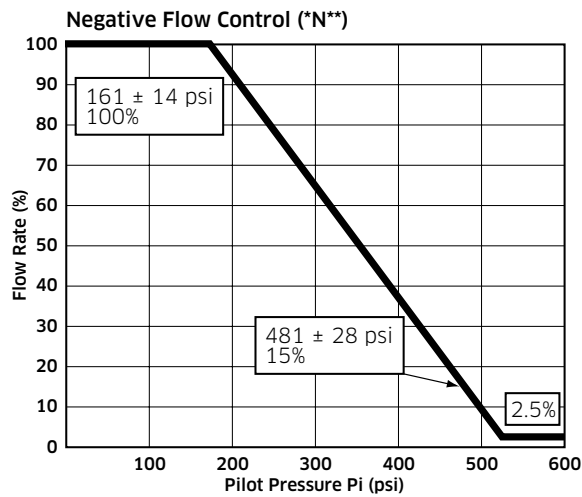
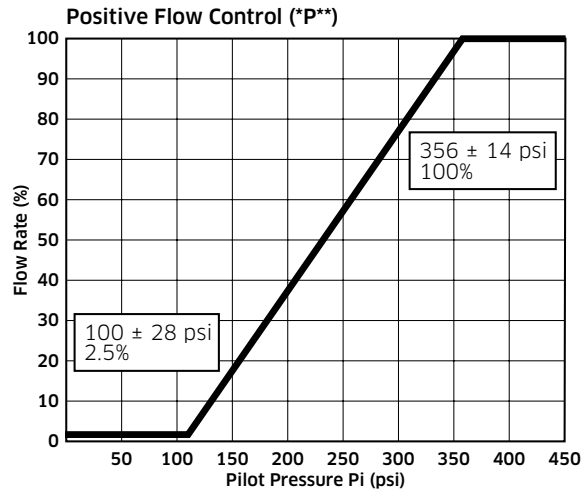

2-5 Performance Data (cont)

Displacement Control Curves

◆ K3VG180/180DT

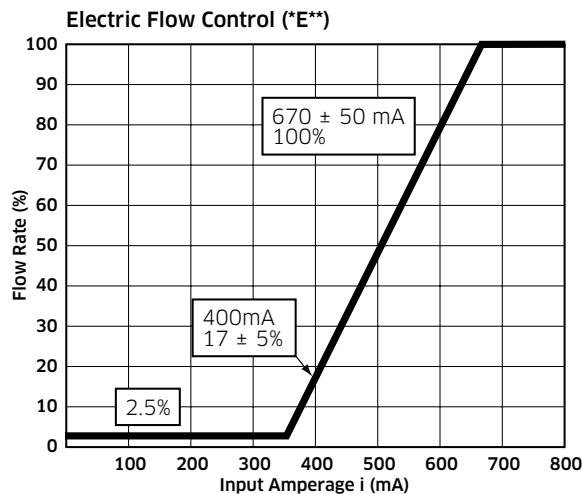
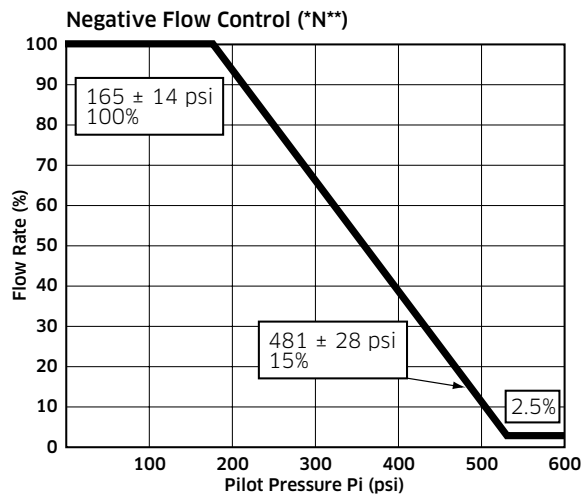
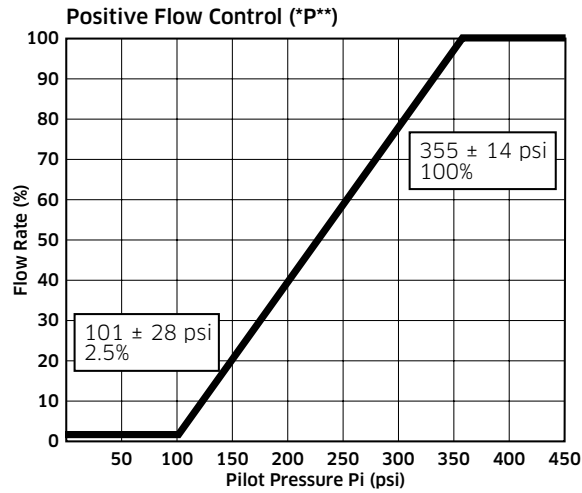

2-5 Performance Data (cont)

Displacement Control Curves

◆ K3VG280/280DT

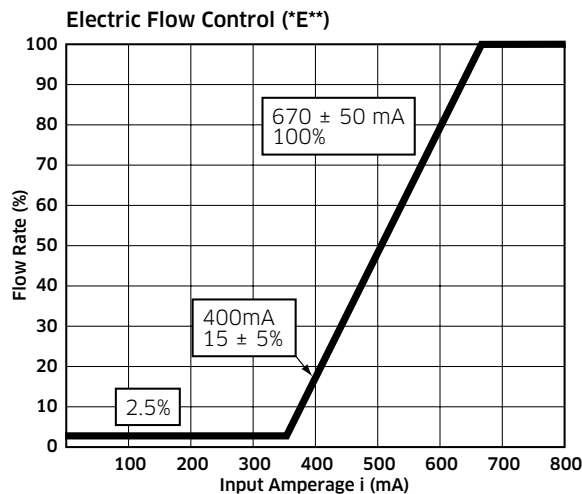
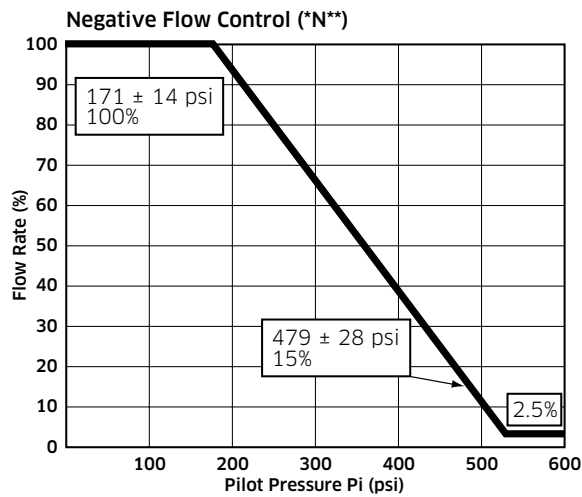
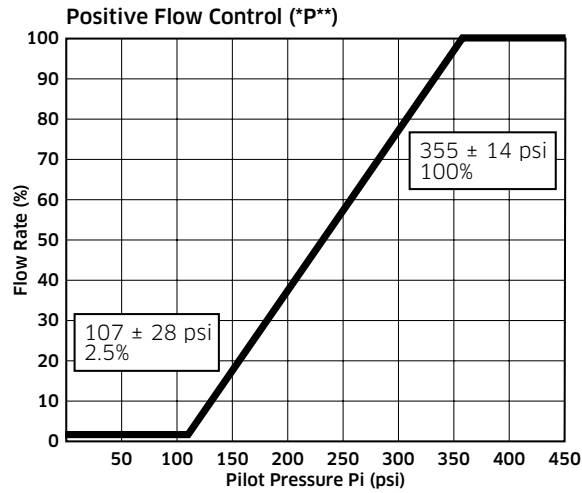

2-6 Bearing Life

◆ K3VG63

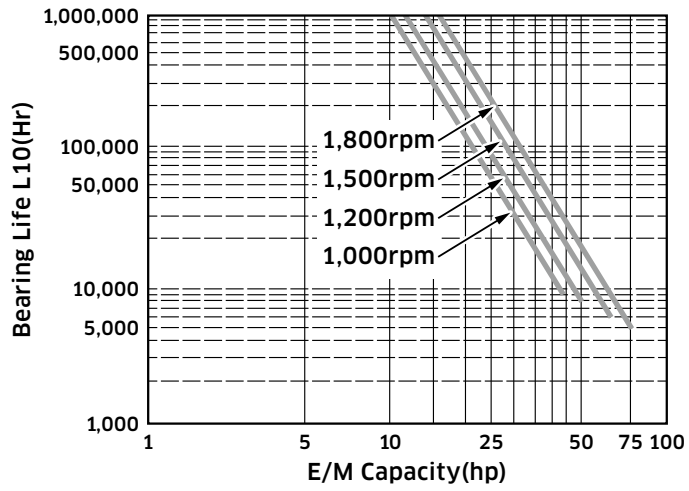

◆ K3VG112

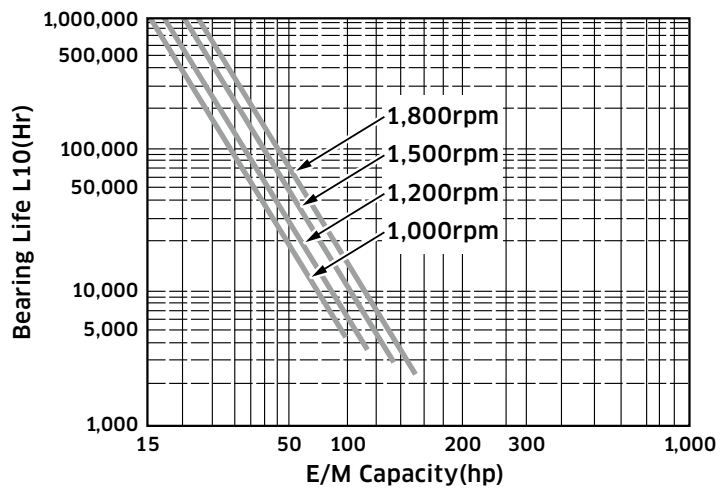

2-6 Bearing Life (cont)

◆ K3VG180/180DT

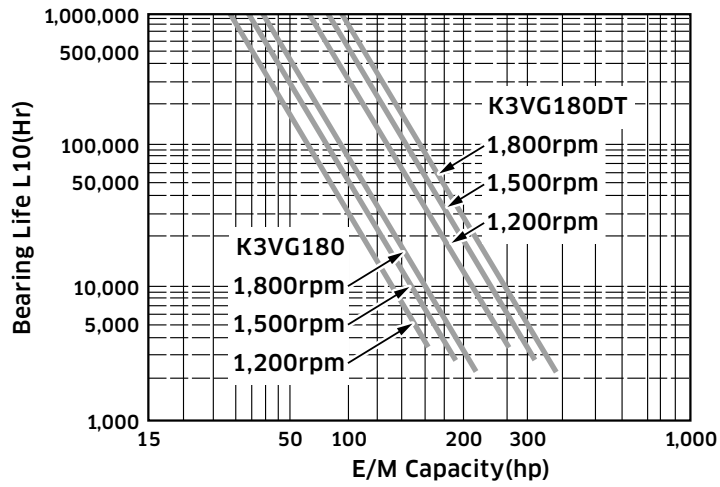

◆ K3VG280/280DT

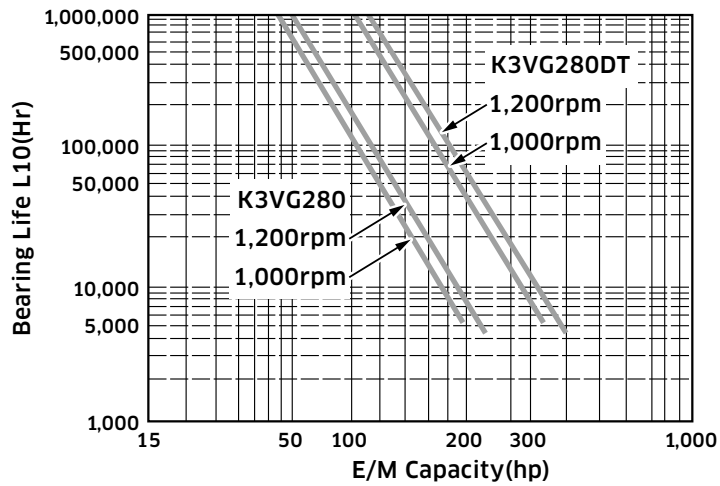

2-7 Installation

◆ Pump Mounting Options

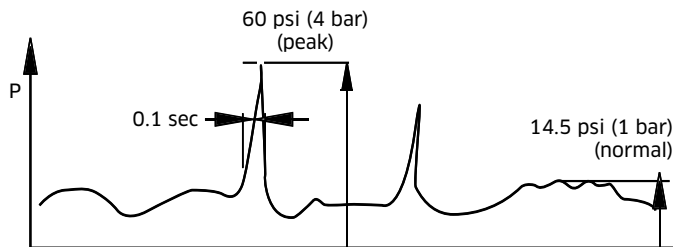
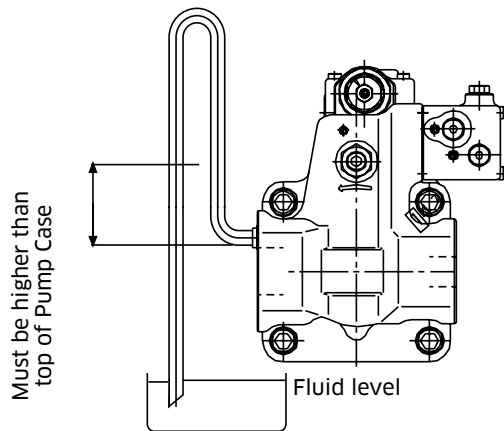

Drain line

It is the preferred option to mount the pump with the case drain piping initially rising above the pump before continuing to the tank. Do not connect the drain line to the inlet line.

Cautions

- A)** Height from the oil level to the centre of the shaft must be within 3.3 ft (1 meter) maximum. (consult KPM).
- B)** The oil in the pump case must be refilled when the pump has not been operated for one month or longer.

The uppermost drain port should be used and the drain piping should be equal or larger in size than the drain port to minimise pressure in the pump case. The pump case pressure should not exceed 14.5 psi (1 bar) as shown in the illustration below. (Peak pressure should never exceed 60 psi (4 bar).)

Mounting the Pump Above the Tank

If the pump is to be mounted above the level of the tank the suction line must initially rise above the level of the pump before continuing to the tank as shown in the illustration below. The “goose neck” configuration is required because there is a very small bleed orifice between the case and the suction line within the valve plate as such one needs this inlet condition to ensure case oil is not drained. The maximum allowable height the pump can be mounted above the tank is 3.3 feet (1 meter). The minimum suction pressure should be -1.45 psi (-0.1 bar) or above.

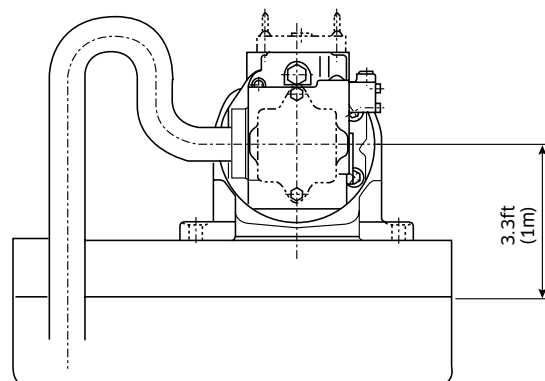
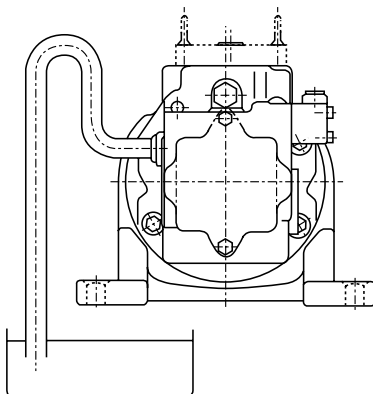

2-7 Installation (cont)

Mounting the pump vertically (shaft up)

For applications requiring vertical installation (shaft up) the pump must be provided with additional means to lubricate the front bearing. Do not use a standard pump for this type of application. (Mounting orientation "V" type should be used.)

The oil level in the tank should be higher than the pump mounting flange as shown in illustration [a] below. If the oil level in the tank is lower than the pump mounting flange then forced lubrication is required through the air bleed port (0.25 - 0.50 GPM [1 - 2 l/min]).

When installing the pump in the tank and submerged in the oil, open the drain port and air bleed port to provide adequate lubrication to the internal components.

When installing the pump outside the tank run piping for the drain and air bleed ports to tank (see illustration [c]). If the drain or air bleed piping rise above the level of oil (see illustration [b]) fill the lines with oil before operation.

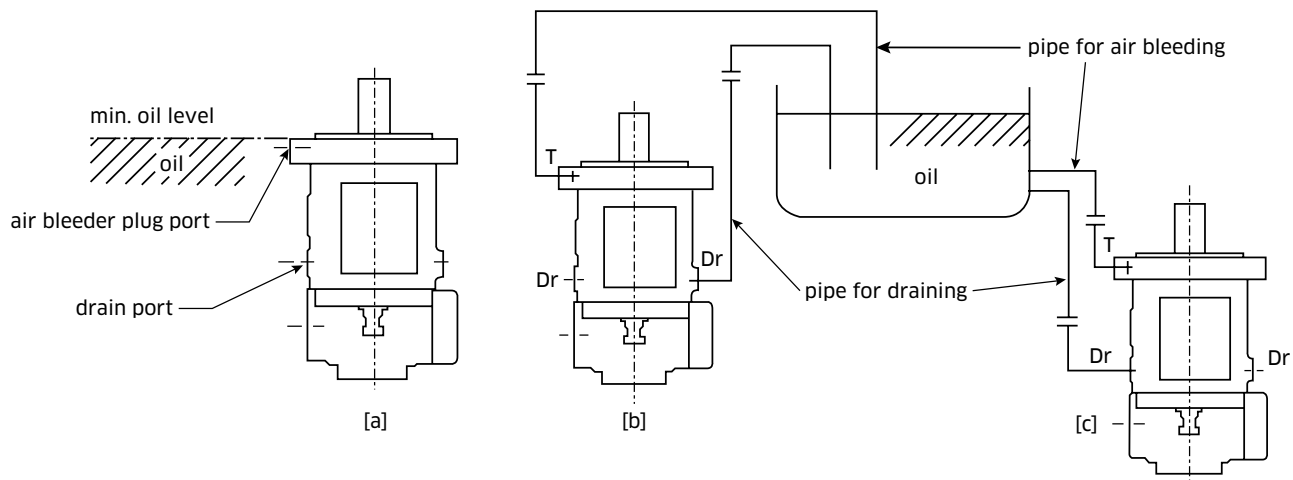

2-7 Installation (cont)

◆ Drive Shaft Coupling

Use a flexible coupling to connect the pump shaft to an engine flywheel or electric motor shaft. Alignment should be within 0.05 mm TIR as shown in the illustration below.

Do not apply any radial or axial loading to the pump shaft. For applications where radial or side loads exist please contact KPM for recommendations.

Do not force the coupling on or off the pump shaft. Use the threaded hole in the end of the pump shaft to fix or remove the coupling.

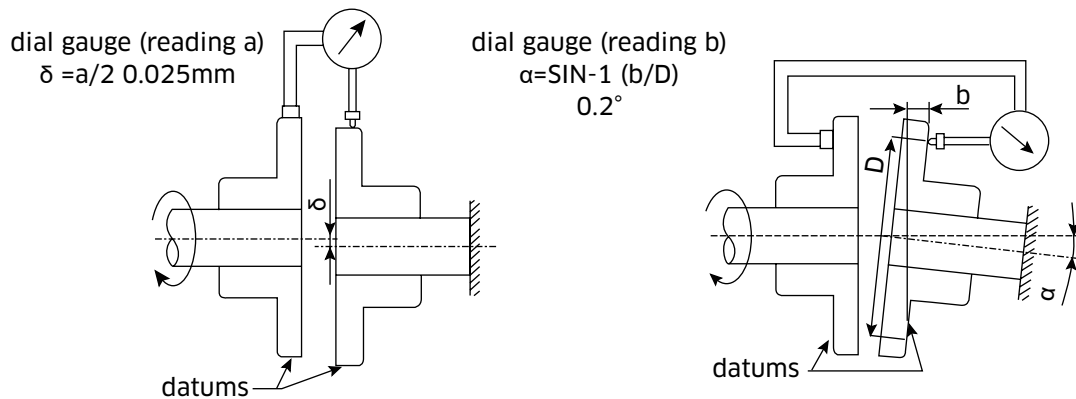

For engine drives a split type pinch bolt drive flange and flexible coupling is recommended.